

# Beaumont

Origination: 8/5/2021  
Effective: 8/5/2021  
Last Approved: 7/6/2021  
Last Revised: 7/6/2021  
Next Review: 7/6/2023  
Document Contact: *Billie Ketelsen: Mgr  
Laboratory*  
Area: *Laboratory-Blood Bank*  
Key Words:  
Applicability: *All Beaumont Hospitals*

## ORTHO VISION Analyzer Maintenance

Document Type: Procedure

### I. PURPOSE AND OBJECTIVE:

The purpose of this procedure is to provide stepwise directions to perform maintenance of the ORTHO VISION™ Analyzer. The ORTHO VISION™ Analyzer has a maintenance screen that allows for the viewing and managing of the maintenance tasks that must be performed on a daily, weekly and monthly basis. All required maintenance must be completed when indicated to keep the ORTHO VISION™ Analyzer operating at an optimal level.

### II. DEFINITIONS:

- A. **Maintenance Mode:** Maintenance mode is an instrument state that is safe for maintenance tasks to be executed. The system must be in maintenance mode in order for maintenance tasks to be performed.
- B. **Maintenance Wizards:** Guided procedures that provide step by step instructions to assist you in the completion of maintenance tasks.

### III. REAGENTS / SUPPLIES / EQUIPMENT:

- A. Clean, lint free cloths
  - 1. Note: Kimwipes\* KIMTECH SCIENCE\* Brand wipes are the only cloths used on the ORTHO VISION™
- B. 0.1M NaOH (Labeled with *Sodium Hydroxide Sticker*)
- C. 7% BSA
- D. 70% isopropyl alcohol
- E. Buffered saline
- F. Deionized (DI) water
- G. Clean, empty 16 x 100 sample tube
- H. Cotton swabs
- I. 10 mL bottle with an attached barcode
- J. Wood applicator sticks

## IV. INSTRUCTIONS:

All maintenance activities must be documented on *ORTHO VISION™ Analyzer Maintenance and Quality Control (QC) Log*. All maintenance tasks must be completed successfully. If maintenance is not completed on time, then the results are flagged and an error message is displayed on the screen.

### Maintenance Schedule:

- A. Daily Maintenance must be performed on each day that the instrument will be used and documented on *ORTHO VISION™ Analyzer Maintenance and QC Log*.
- B. Weekly Maintenance must be performed at weekly intervals and documented on *ORTHO VISION™ Analyzer Maintenance and QC Log*.
  - 1. Note that all daily maintenance activities must also be performed after the weekly maintenance procedure.
- C. Monthly Maintenance must be performed at monthly intervals and documented on *ORTHO VISION™ Analyzer Maintenance and QC Log*.
  - 1. Note that all weekly and daily maintenance activities must also be performed after the monthly maintenance as indicated by the maintenance schedule.
- D. Yearly or Preventative Maintenance must be scheduled and performed by a user with the required access or the *ORTHO VISION™* Service Representative on an annual basis. This maintenance will be documented on *ORTHO VISION™ Analyzer Yearly and As-Needed Maintenance Log*.
  - 1. A copy of the Ortho Clinical Diagnostics (OCD) representative's report will be filed and saved in an appropriate location.
- E. As-Needed Maintenance of the *ORTHO VISION™* will be performed by each shift on an as-required basis and documented on *ORTHO VISION™ Analyzer Yearly and As-Needed Maintenance Log*.

## V. PRECAUTIONS AND SPECIAL NOTES:

### A. Precautions.

- 1. Assume that all used equipment is contaminated with potentially infectious biological material. Wear gloves, closed shoes, buttoned lab coats, and eye protection when the system is cleaned and maintained. Treat all waste materials used in the cleaning process as contaminated. Handle all equipment with care. Mechanical parts may have edges, pinch points, and corners that potentially could cause injury. Liquid may drip from disconnected tubing. If necessary, use an absorbent material to absorb the drops of liquid.

### B. Maintenance Mode.

- 1. The system must be in Maintenance Mode in order for Maintenance Tasks to be performed.
  - a. Maintenance Mode is an Instrument State that is safe for Maintenance Tasks to be executed and is displayed in the top-center of the screen.
  - b. When in Maintenance Mode, the Maintenance screen is available.
  - c. The Maintenance Tasks and Action Buttons on the screen are active.
  - d. System doors are monitored so that the appropriate inventory and initialization processes can be performed once Maintenance Tasks have been completed.

- e. To exit Maintenance Mode and return the system to the Operational state, touch the Home Menu button.
2. To enter Maintenance Mode:
    - a. Touch the Stop Processing button. The system will ask if you want an Urgent Stop or Stop Processing. Touch Stop Processing.
    - b. Touch the Maintenance menu button.
    - c. Touch the Enter Maintenance Mode.
    - d. Select the desired maintenance frequency.
    - e. Select the desired maintenance task.
    - f. Touch the Execute action button.



### C. Maintenance Wizards.

1. Maintenance Wizards are guided procedures that provide step by step instructions to assist you in the completion of Maintenance Tasks.
  - a. To display a Maintenance Wizard, select a Maintenance Task and touch Execute.
  - b. The Maintenance Wizard displays steps and images for each Maintenance Task.
  - c. For a Maintenance Task to be successfully executed, each step must be completed.
  - d. If the Maintenance Wizard is closed before all the steps are completed, you must start the task over again.
  - e. Use the Action Buttons located in the black bar, below the images, to advance through the steps.

## VI. PROCEDURE:

### A. Daily Maintenance.

1. Verify that the system is in Maintenance Mode before Maintenance Task is executed.
2. The Maintenance Task, listed below, is the default daily maintenance task for the system.
3. Daily maintenance tasks routinely require no more than 20 minutes, in total, to complete.
4. Daily maintenance must be performed every day by a technologist after weekly or monthly maintenance as indicated by the maintenance schedule.
5. Depending on the volumes present on the instrument, it may prompt you to empty the liquid waste and refill the buffered saline and DI water when starting daily maintenance. If this occurs, follow the prompts and continue with daily maintenance as directed afterwards.
6. **Daily Probe Decontamination.**

- a. When prompted open the load station door.

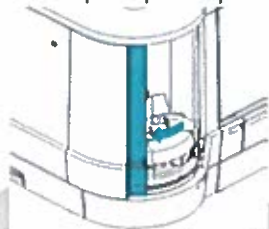

- b. Add 5 mL of 0.1 NaOH to a 10 mL vial with an attached barcode and *Sodium Hydroxide Sticker*. Verify the barcode is facing out.



- c. Place the vial into position 3 of the diluent rack. Rack positions are numbered from right to left.

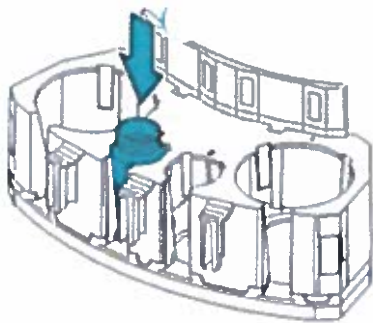

- d. Place a new 5 mL of 7% BSA into position 2 of the same diluent rack as the NaOH and load the diluent rack on to the instrument. Make sure there are no bubbles present in the BSA and that the reagent has been brought to room temperature prior to use (bubbles can be mistaken as clots by the instrument during daily QC).

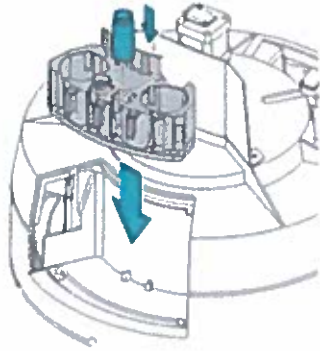

- e. Close the load station door.
- f. When prompted, open the maintenance door.

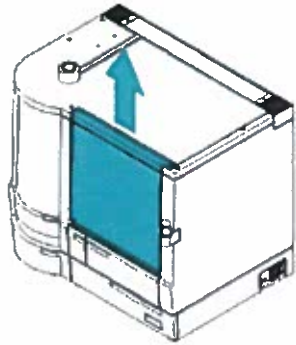

- g. Clean the probe with a Kim wipe moistened with 70% isopropyl alcohol. Be careful not to bend the probe.

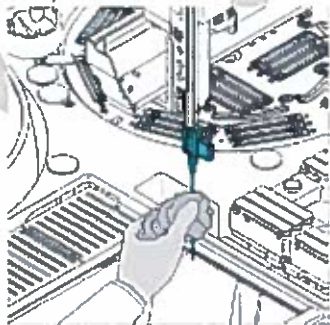

- h. Close the maintenance door. The system will automatically complete the decontamination.
- i. When prompted, open the load station door.

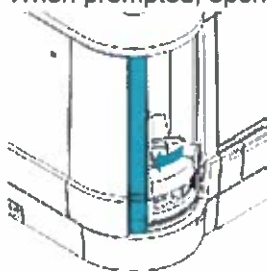

- j. Remove the diluent rack and close the load station door.

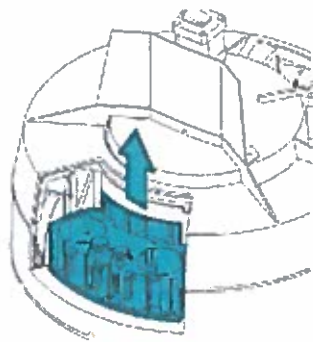

7. **Rotate and Evaluate Reagents.** The operator is responsible for monitoring the length of time the reagents have been on the analyzer. The Reagent screen allows you to review current inventory information for the reagents loaded on the system. Reagents have varying stability on the analyzer. Each reagent loaded must be checked to verify it is within its expiration date and it has not exceeded the reagents on-board stability. The system will not notify the operator if the reagents have exceeded their on board stability.

a. MTS Diluent 2™ and MTS Diluent 2 PLUS™.

- i. Freshly opened and previously opened diluent can be kept on the analyzer up to 24 hours of continuous use.
- ii. The “open date” and the technologist’s initials must be written on each diluent bottle upon opening. The diluents must be used within one month from the “open date” on the bottle.
- iii. Diluents must be inspected and rotated by a technologist and discarded according to parameters in Transfusion Medicine policy ORTHO VISION™ Analyzer QC. Verify there is no evidence of discoloration, turbidity, or sign of contamination in the diluent bottles.

b. 0.8% AFFIRMAGEN® and 0.8% SELECTOGEN®

- i. Freshly opened Ortho Reagent Red Blood Cells (RBCs) have been validated for continuous use on-board the system for 5 days when using the ORTHO VISION™ Evaporation Caps. The “open date” and the technologist’s initials must be written on each reagent vial. This “open date” must be checked to verify the reagent has not been on the instrument for more than 5 days.
- ii. The cells must be gently rolled/swirled to mix until the reagent RBCs are completely suspended in the diluent.
- iii. Remove any bubbles from the surface of the reagent.
- iv. Reagent RBCs must be at room temperature when they are loaded.
- v. Reagent RBCs must be inspected daily by a technologist and replaced / discarded according to parameters in ORTHO VISION™ Analyzer QC.

c. Loading / Unloading Reagents.

- i. Touch Resources.



- ii. Touch Reagents.



iii. Touch quadrant 1, 2, 3, or 4.

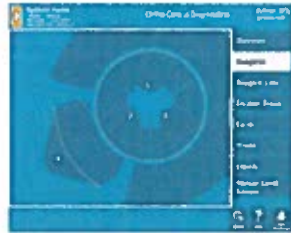

iv. Touch Load/Unload and load or unload your rack.

v. Close the load station door.

## B. Weekly Maintenance.

1. Weekly maintenance tasks routinely require no more than 30 minutes to complete.
2. Be sure the system is in Maintenance Mode before maintenance tasks are executed.
3. Select Weekly Maintenance and push Execute.
4. Follow the Maintenance Wizard through the following steps to complete weekly maintenance.
5. Weekly maintenance must be completed before performing daily maintenance and after monthly maintenance (if indicated).
6. **Weekly Liquid System Decontamination and Pump Test.**
  - a. Open the liquids door and pull the bottle release for the liquid waste bottle.

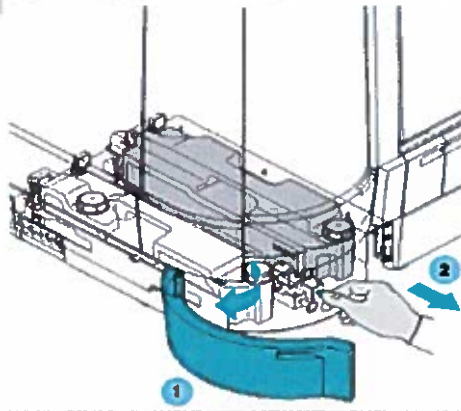

- b. Remove the liquid waste bottle from the system.
- c. Remove the cap from the liquid waste. Pour the liquid waste down the drain of a "dirty" sink. Flush with water.

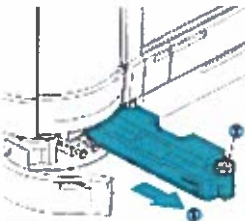

- d. Install a dry bottle cap and slide the liquid waste bottle into the system with the bottle insertion tool until it snaps into place.

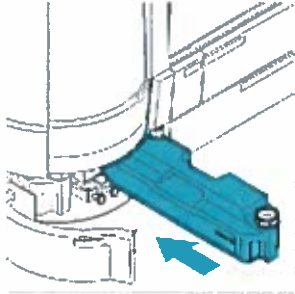

- e. Pull the bottle release for the liquid container.

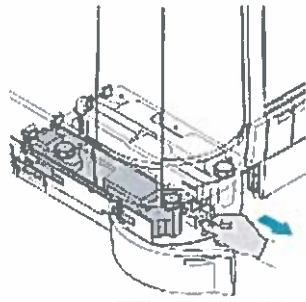

- f. Remove the liquid container from the system. Remove the 2 bottle caps. Dispose of the residual liquids in a "dirty" sink.

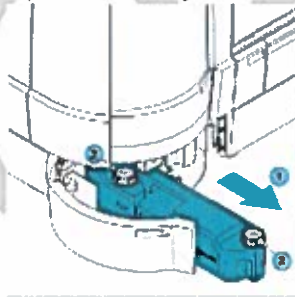

- g. Fill the smaller bottle (blue) with approximately 400 mL of 70% isopropyl alcohol and fill the larger bottle (white) with approximately 600mL of 70% isopropyl alcohol.

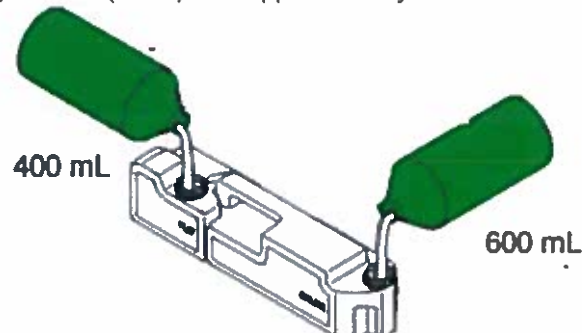

- h. Install the bottle caps and gently tilt side to side. Push the bottle back into the system with the bottle insertion tool until it snaps into place. Close the door. The system will perform the decontamination.



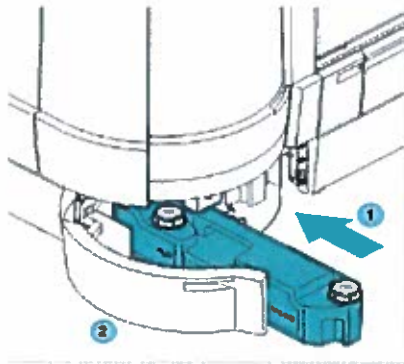

- i. When prompted, open the liquids door and pull the bottle release for the liquid container.
- j. Remove the liquid container from the system. Remove the 2 bottle caps. Dispose of the liquids down the drain. Flush with water.

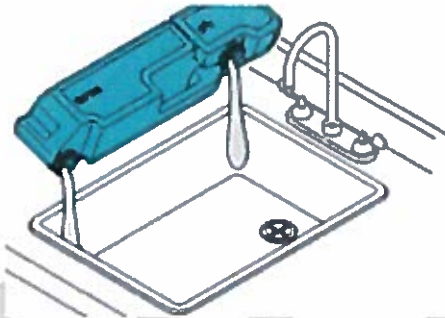

- k. Fill the smaller BOTTLE (blue) with approximately 500 mL of deionized water and the larger bottle (white) with approximately 3000 mL of DI water. Install the bottle caps.

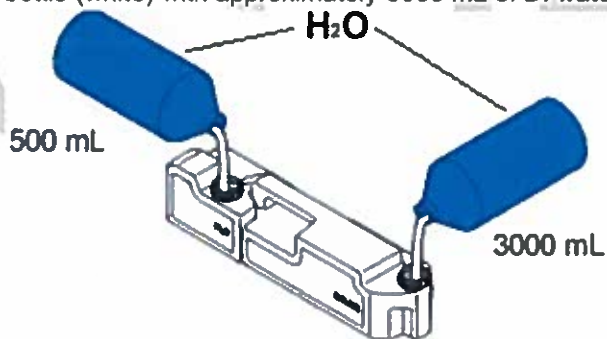

- l. Gently tilt side to side to rinse. Remove the 2 bottle caps and dispose of the liquids.



- m. Fill the smaller bottle (blue) with approximately 900 ml deionized water and the larger bottle (white) with approximately 4700 ml of buffered saline. Install the bottle caps.

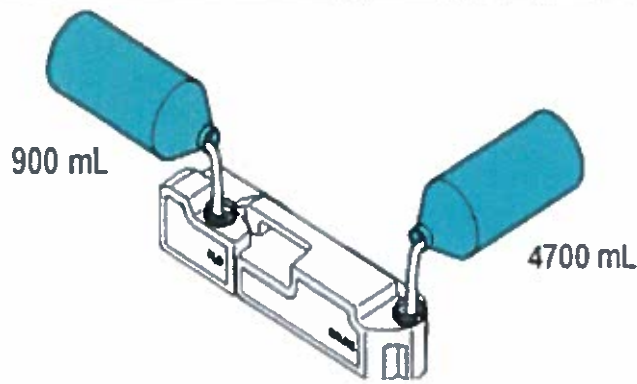

- n. Push the bottle back in with the bottle insertion tool, until it snaps into place. Close the door.

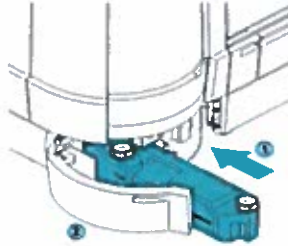

- o. Open the liquids door and pull the bottle release for the liquid waste. Remove the liquid waste bottle from the system.

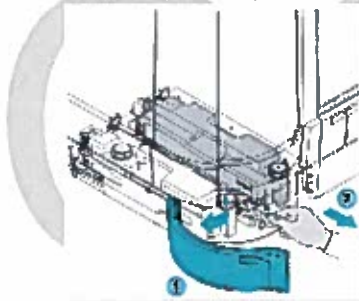

- p. Remove the bottle cap and dispose of the liquid waste.

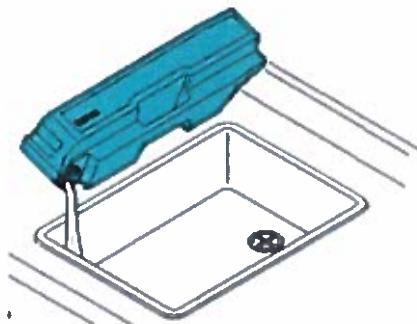

- q. Fill the liquid waste bottle at least half full with tap water. Install the bottle cap and gently tilt side to side to rinse.

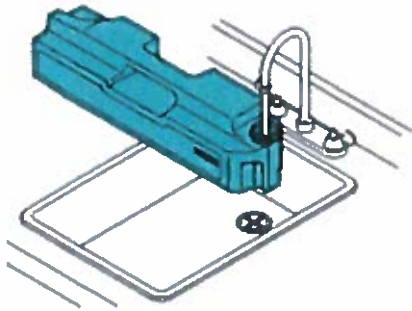

- r. Remove the bottle cap and dispose of the liquid.

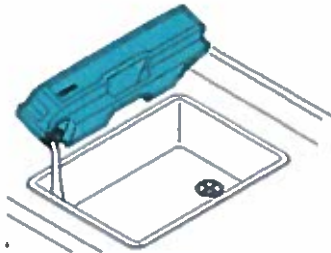

- s. Install the bottle cap and push the liquid waste bottle into the system with the bottle insertion tool until it snaps into place.

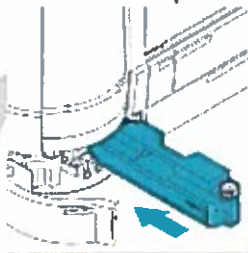

- t. When prompted, open the load station door.

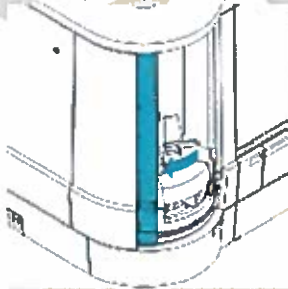

- u. Place an empty 16 x 100 sample tube into position 1 of an appropriate green sample rack. Load the sample rack. Close the load station door.

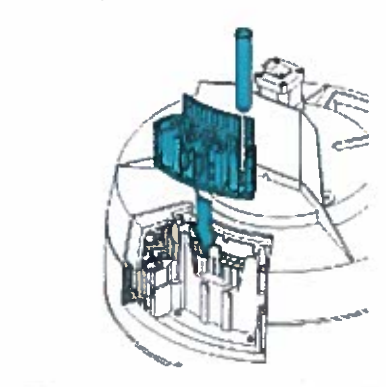

- v. When prompted, open the load station door.

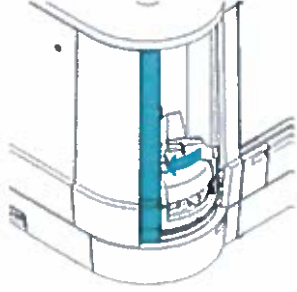

- w. Remove and empty the sample tube. Place the empty sample tube back into the sample rack at position 1.

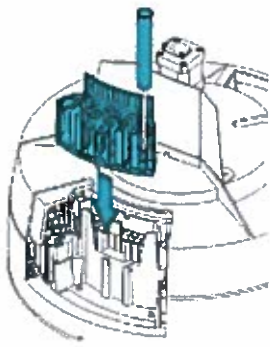

- x. Close the load station door. When prompted, open the load station door. Remove the sample rack and sample tube.

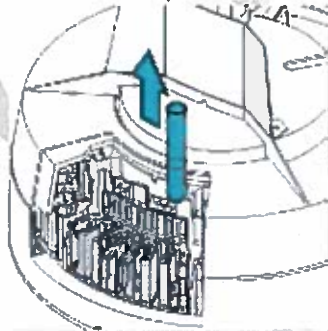

- y. Close the load station door.

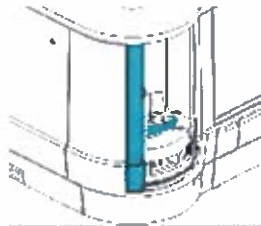

## 7. Shutdown and Startup of the ORTHO VISION™ Analyzer.

- a. **Shutdown:** Use these steps to perform an orderly shutdown of the system. To optimize the next startup, clear the error code list prior to shutdown.
- Remove all sample, reagents and cards (in both the dual purpose and supply drawers) from the analyzer.
  - Touch the Home menu button.



- iii. Touch the Shutdown action button. A confirmation screen is displayed.



- iv. Touch Yes to confirm the shutdown procedure. Shutdown processing will automatically begin.
- v. Confirm that the green light under the monitor is blinking and that the “No Signal Detected” message has displayed.
- vi. Power off the analyzer.
  - a. Use the power switch located on the right side of the analyzer.
- b. **Startup:** Use these steps to perform a startup of the system. System reagents and samples are not loaded on the analyzer until Startup is complete.
  - i. Confirm the card waste tray is empty.
  - ii. Confirm the load station is empty.
  - iii. Confirm there are no reagents on board.
  - iv. Close all analyzer doors.
  - v. Press the ON switch.
  - vi. A normal system startup leaves the system in Operational state. The system will perform a device and consumables inventories. The system will post an error for the Incubator (37°C) ring until the temperature is reached.

### C. **Monthly Maintenance.**

1. Monthly Maintenance Tasks routinely require no more than 60 minutes, in total, to complete.
2. Be sure that the system is in Maintenance Mode before any Maintenance Tasks are executed.
3. This procedure is accessed using system maintenance. Complete each task as prompted using the system software.
4. After performing Monthly Maintenance continue to Weekly Maintenance (if indicated by the maintenance schedule) and Daily maintenance.
5. Perform a monthly computer backup as part of routine monthly maintenance.
6. **Instrument Cleaning.**
  - a. Open the load station door.
  - b. Remove all racks and trays from the agitated (inner) and non-agitated (outer) rotors.

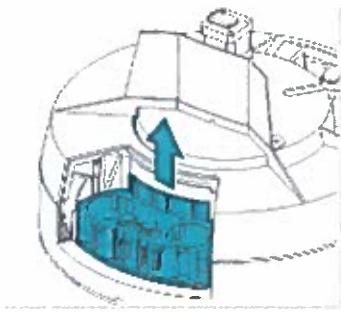

- c. Clean all positions of the agitated (inner) and non-agitated (outer) rotors.
  - i. Do not remove the rotor cover.
  - ii. Wipe rotors using a lint-free cloth moistened with 70% isopropyl alcohol.
  - iii. Rotating inner and outer rotors allows access to all rotor positions.



- d. Clean the racks and cap holders using a lint-free cloth moistened with 70% isopropyl alcohol. Wipe the alcohol from the racks and cap holders using a lint-free cloth moistened with deionized water.
  - i. Use a cotton swab dipped in 70% isopropyl alcohol to clean areas of the racks that are difficult to reach. Then wipe with a cotton swab moistened with DI water.

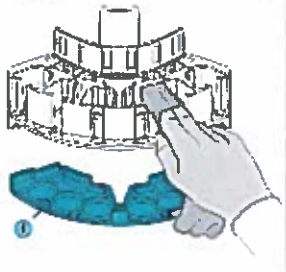

- e. Open the maintenance door.

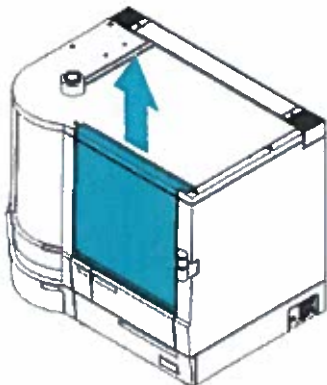

f. Remove both centrifuge covers.

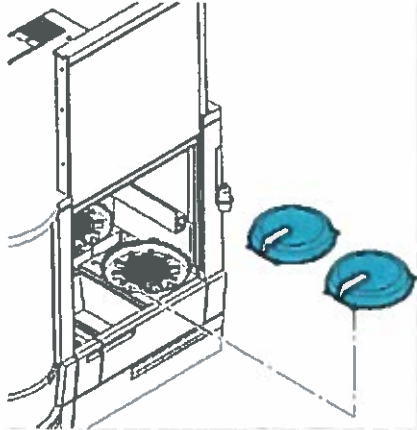

g. Clean all surfaces of both centrifuges. Remove and clean centrifuge cards holders.

- i. Replace centrifuge card holders and centrifuge covers when cleaning is complete.
- ii. Use alcohol dabbed Kim wipes wrapped around applicator stick to clean inside card holders.

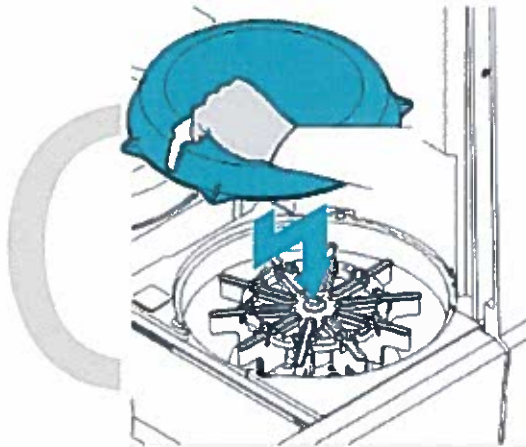

h. Clean all surfaces of the incubator.

- i. Use an alcohol-dabbed Kim wipe.
- ii. Rotating the incubator allows access to entire incubator surface.

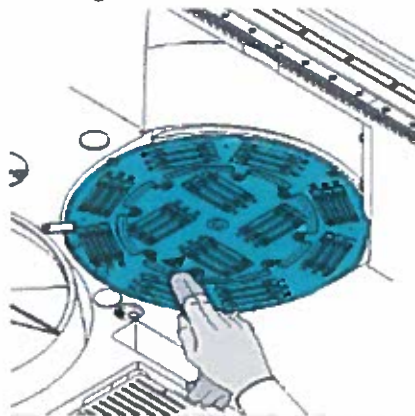

i. Close the maintenance door.

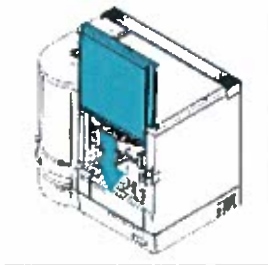

- j. Open the load station door.
  - i. The load station will move to the reagent rack load position.

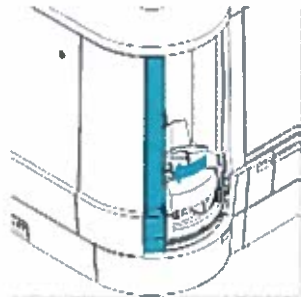

- k. Load an empty NAA reagent rack (labeled N02B).
  - i. The load station will move to the reagent rack load position.

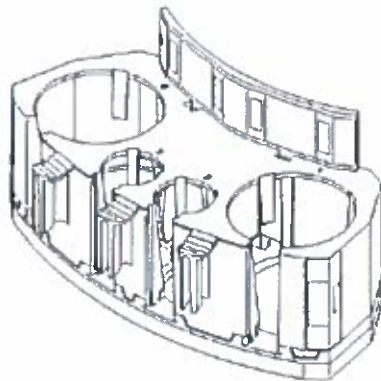

- l. Load an empty 10 mL reagent rack (labeled R10b). Close the load station door.
  - i. "The test completed successfully" message will appear.

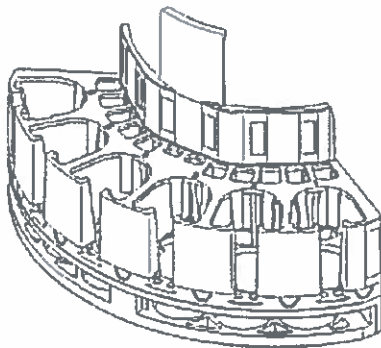

- m. Open the load station.



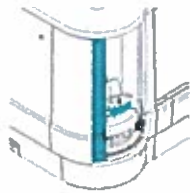

- n. Unload the empty reagent rack.
- o. The load station will move to the reagent rack load position.
- p. Unload the empty reagent rack and close the load station door.
- q. Open the liquids door.



- r. Remove the small square foam filter from the air input fan.
- s. Gently rub both sides of the filter using your fingers until the dust/lint is removed.
- t. Place the foam filter back into the air input fan.
- u. Close the liquids door, and click NO on the screen when asked if the liquid supplies have been filled and the liquid waste emptied.
  - i. You are not actually filling up the liquid supplies or emptying the liquid waste at this step, just gaining access to the compartment.
- v. Proceed to the next scheduled maintenance.
  - i. Weekly or daily maintenance as indicated by maintenance schedule.

**7. Monthly Backup.**

- a. Select the Maintenance menu button at the top and then touch Enter Maintenance Mode.



- b. Hit the Monthly tab on the right, and select the Backup task. Hit Execute at the bottom once you have selected the backup.



c. Hit Ok to start the backup.

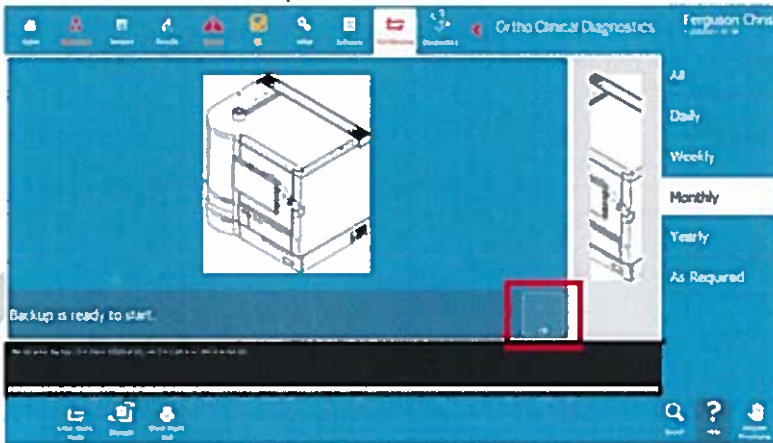

d. Hit Ok again once it says "Backup file saved."

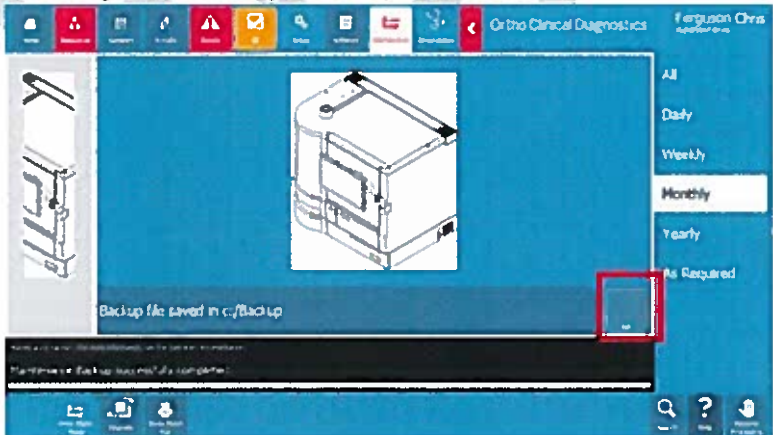

#### D. Yearly Maintenance.

1. Only users with the required access or the ORTHO VISION™ Service Representative are permitted to perform the Yearly Maintenance Tasks listed on the Yearly Maintenance screens and log.
2. The Maintenance Tasks, listed below, are the default Yearly Maintenance Tasks for the system:
  - a. Replace System Liquid Container.
  - b. Replace Pipetting Tubing.
  - c. Replace Instrument Fan Filter.

- d. Replace Diluter Valve and Syringe.
- e. Replace System Tubing.

**E. As-Needed Maintenance.**

1. Users with the required access rights will perform As Required Maintenance.
2. The Maintenance Tasks, listed below, are the default As-Needed Tasks for the system:
  - a. Replace Liquid Waste Container.
  - b. Replace Centrifuge 1 Card Holders.
  - c. Replace Centrifuge 2 Card Holders.
  - d. Imaging System Cleaning-Operator
  - e. Pipetting Probe Adjustment.
  - f. Prepare System for Downtime.
  - g. Fill Liquid System – Buffered saline.
  - h. Unlock/open and Close/Lock all Doors.
  - i. Empty Liquid System.
  - j. Virus Scan.
  - k. Probe Replacement.
  - l. Pipetting Volume Test.
  - m. Liquid System Decontamination.
  - n. Pump Test.
  - o. Configure handheld barcode Scanner.
  - p. Maintenance Backup.
3. Be sure that the system is in Maintenance Mode before any Maintenance Tasks are executed.
4. Refer to the maintenance procedures provided in the ORTHO VISION™ Self Service Customer Procedure Guide or in the Library in the analyzer software.
5. If you still need assistance, or there are any unexpected errors or problems, contact Ortho Care Technical Solutions at 1-(800)-421-3311, Prompts 2 / 3. Document *ORTHO VISION™ Analyzer Problem Log* if applicable.

## VII. REFERENCES:

- A. AABB. (2020) *Standards for Blood Banks and Transfusion Services*.(Current Edition). AABB.
- B. Cohn, C.S., Delaney, M, Johnson, S.T., Katz, L.M. (2020) *Technical Manual*.(19<sup>th</sup> ed.). AABB.
- C. Ortho Clinical Diagnostics, Rochester, NY, Ortho Vision General Operator Training Manual, Publication J56102.
- D. ORTHO VISION™ Analyzer ID-MTS Gel Cards Reference Guide J40050 (2015).
- E. ORTHO VISION™ Analyzer ID-MTS Gel Cards Self-Service Customer Procedures Guide J40055ENNA (2015).
- F. ORTHO VISION™ Analyzer Electronic Library, Software version 5.3.0.0.

G. Ortho Clinical Diagnostics, Rochester, NY, Electronic Publication number J56102.

H. ID-Micro Typing System® Implementation Guide 6902200 (2015).

## Attachments

[ORTHO VISION Analyzer Maintenance and QC Log](#)

[ORTHO VISION Problem Log](#)

[Sodium Hydroxide Sticker](#)

## Approval Signatures

Step Description	Approver	Date
	Jeremy Powers: Chief, Pathology	7/6/2021
	Ann Marie Blenc: System Med Dir, Hematopath	7/2/2021
	Vaishali Pansare: Chief, Pathology	6/25/2021
	Ryan Johnson: OUWB Clinical Faculty	6/25/2021
	Muhammad Arshad: Chief, Pathology	6/23/2021
	John Pui: Chief, Pathology	6/23/2021
Policy and Forms Steering Committee (if needed)	Billie Ketelsen: Mgr Laboratory	6/23/2021
Policy and Forms Steering Committee (if needed)	Gail Juleff: Project Mgr Policy	6/22/2021
	Craig Fletcher: System Med Dir, Blood Bank	6/22/2021
	Anji Miri: Supv, Laboratory	6/10/2021
	Michael Rasmussen: Supv, Laboratory	5/20/2021
	Karrie Torgerson: Supv, Laboratory	5/18/2021
	Teresa Lovins: Supv, Laboratory	5/14/2021
	Kelly Sartor: Supv, Laboratory	5/12/2021
	Billie Ketelsen: Mgr Laboratory	5/12/2021
	Billie Ketelsen: Mgr Laboratory	5/12/2021

## Applicability

Dearborn, Farmington Hills, Grosse Pointe, Royal Oak, Taylor, Trenton, Troy, Wayne



ORTHO VISION™ Analyzer Maintenance and QC Log

**Weekly Maintenance Record**

Month / Year \_\_\_\_\_

ORTHO VISION™ Analyzer ID #: \_\_\_\_\_

Task	Date / Tech	Date / Tech	Date / Tech	Date / Tech
Liquid System Decontamination and Pump Test				
Perform Shutdown and Startup				
Wipe Down Exterior				
<i>After completing weekly maintenance on the VISION™, the daily maintenance must be completed prior to testing patient samples.</i>				

Review by / date: \_\_\_\_\_

**Monthly Maintenance Record**

Month / Year \_\_\_\_\_

ORTHO VISION™ Analyzer ID #: \_\_\_\_\_

Task	Date	Tech
Instrument Cleaning		
Image System Cleaning		
Backup		
<i>After completing monthly maintenance on the VISION™, the weekly maintenance and/or the daily maintenance (as indicated) must be completed prior to testing patient samples.</i>		

Review by / date: \_\_\_\_\_

ORTHO VISION™ Analyzer Problem Log

ORTHO VISION™ Analyzer ID #: \_\_\_\_\_

Date / Time	Tech	Problem or Reason for Service Call	Resolution (Include actions taken by technologist. If a service call is placed, document any applicable information regarding follow-up actions or service visits)

The contact number for Ortho Care Technical Solutions / VISION™ is: (800) 421-3311, Prompts 2 / 3

Reviewed by / date: \_\_\_\_\_

