

TRAINING UPDATE

Lab Location: SGMC & WOMC
Department: Core Lab

Date Distributed: 10/15/2019
Due Date: 11/6/2019
Implementation: 11/6/2019

DESCRIPTION OF PROCEDURE REVISION

Name of procedure:	
Urinalysis by Clinitek® AUWi PRO System SGAH.U900 v3	
Description of change(s):	
<i>Major changes to SOP are highlighted:</i>	
Section	Reason
4.1, 4.2	Added 1.0N NaOH
4.2	Corrected bleach dilution steps
5.3	Changed 5.25% to 'diluted bleach'
8.2	Updated NaOH instructions
10.6	Updated pH code and interpretation
15	Added NaOH hazard
Add 1	Changed SRV cleaning to weekly (UF log already includes this)
Add 3	Changed settings for cast & crystals (already changed in instruments)
This revised SOP will be implemented on November 6, 2019	

Document your compliance with this training update by taking the quiz in the MTS system.

Technical SOP

Title	Urinalysis by Clinitek® AUWi PRO System	
Prepared by	Ashkan Chini, Hollie Genser	Date: 7/15/2019
Owner	Robert SanLuis	Date: 7/15/2019

Laboratory Approval		Local Effective Date:
Print Name and Title	Signature	Date
<i>Refer to the electronic signature page for approval and approval dates.</i>		

TABLE OF CONTENTS

1.	Test Information	2
2.	Analytical Principle	2
3.	Specimen Requirements	2
4.	Reagents	4
5.	Calibrators/Standards	6
6.	Quality Control	7
7.	Equipment And Supplies	9
8.	Procedure	10
9.	Calculations	14
10.	Reporting Results And Repeat Criteria	14
11.	Expected Values	19
12.	Clinical Significance	20
13.	Procedure Notes	26
14.	Limitations Of Method	26
15.	Safety	28
16.	Related Documents	28
17.	References	28
18.	Revision History	29
19.	Addenda	29

1. TEST INFORMATION

Assay	Method/Instrument	Test Code
Urinalysis	Clinitek Novus® / Siemens UF1000i™	UAI

Synonyms/Abbreviations
UA, Urine, Urine Microscopic, Urine Macroscopic, UA Micro, UA Macro

Department
Urinalysis

2. ANALYTICAL PRINCIPLE

Urinalysis describes a group of qualitative or semi quantitative tests performed on a random, non-timed urine specimen using the Clinitek Novus®. The analyzer is intended for the measurement of the following components in urine: bilirubin, blood (occult), glucose, ketone (acetoacetic acid), leukocytes, nitrite, pH, protein, urobilinogen, and specific gravity. The Clinitek Novus® uses a digital camera that reads the color and intensity of the test pads and converts the results into clinically meaningful units. Specific gravity is determined by the refractive index method. The analyzer also reports the color and clarity of the specimen.

Quantification of microscopic formed elements is performed using the UF1000i™, which is a fully automated urine particle analyzer utilizing flow cytometry measurement of fluorescence and forward light scatter. The elements enumerated by the UF1000i™ are RBCs, WBCs, Squamous Epithelial Cells, Hyaline Casts and Bacteria. Flagged elements are Crystals, Yeast Like Cells (YLC), Pathological Casts, and Small Round Cells.

The Clinitek® AUWi track automatically transports samples from the Clinitek Novus® to the UF1000i™.

3. SPECIMEN REQUIREMENTS

3.1 Patient Preparation

Component	Special Notations
Fasting/Special Diets	N/A
Specimen Collection and/or Timing	Normal procedures for collecting urine may be used for samples to be analyzed by this method. Transfer contents to Urine Collection Kit to better preserve the sample.

Component	Special Notations
Special Collection Procedures	Clean catch specimen preferred. Refer to Urine Collection procedure. A first morning specimen is also preferred but random collections are acceptable.
Other	If Urine Collection Kit is not used, submit to Laboratory within 2 hours of collection.

3.2 Specimen Type & Handling

Criteria	
Type -Preferred -Other Acceptable	Urine, freshly voided Random Urine
Collection Container	Clean or sterile container
Volume - Optimum - Minimum	5.0 mL Clinitek Novus: 2.0 mL UF1000i : 2.0 mL Note: if the total volume is less than 5 mL, the sample must be run in the manual mode. Refer to section 8.
Transport Container and Temperature	Urine Collection Kit (Urine Analysis Preservative Tube preferred) or container at room temperature
Stability & Storage Requirements	Room Temperature: 24 hours in Urine Analysis Preservative Tube
	Refrigerated: 24 hours
	Frozen: Unacceptable
Timing Considerations	Test the urine within two hours after voiding, sooner if testing for bilirubin or urobilinogen
Unacceptable Specimens & Actions to Take	Specimens with volume less than 2 mL cannot be run on this instrument and should be processed using the backup system. Specimens that are visibly bloody or turbid can cause clogs in the pipette or the flow cell and should not be run on this instrument; the backup system must be used for those samples. Specimens that are unlabeled, improperly labeled, or those that do not meet the stated criteria are unacceptable. Request a recollection and credit the test with the appropriate LIS English text code for "test not performed" message. Examples: Quantity not sufficient-QNS; Wrong collection-UNAC. Document the request for recollection in the LIS.
Compromising Physical Characteristics	If specimen refrigerated, let it return to room temperature before testing.
Other Considerations	After testing samples will be held until the next successful QC performance

NOTE: Labeling requirements for all reagents, calibrators and controls include: (1) Open date, (2) Substance name, (3) Lot number, (4) Date of preparation, (5) Expiration date, (6) Initials of tech, and (7) Any special storage instructions. Check all for visible signs of degradation.

4. REAGENTS

The package insert for a new lot of kits must be reviewed for any changes before the kit is used. A current Package Insert is included as a Related Document.

4.1 Reagent Summary

Reagents / Kits	Supplier & Catalog Number
Clinitek Novus® 10 Urinalysis Cassette	Siemens Healthcare Cat. No. 10634643
Clinitek Novus® Rinse Additive	Siemens Healthcare Cat. No. 10697754
Sodium Hypochlorite- Clorox concentrated	Fisher Scientific Cat. No. 509387879 DO NOT USE generic bleach use only Clorox
Reagent Grade Water	Millipore or NERL Thermo Scientific (Cat. No. 0015)
UF II Sheath	Siemens Healthcare Cat. No. 10378290
UFII Pack-Bac	Siemens Healthcare Cat. No. 10378293
UFII Pack-Sed	Siemens Healthcare Cat. No. 10378291
UFII Search-Bac	Siemens Healthcare Cat. No. 10378294
UFII Search-Sed	Siemens Healthcare Cat. No. 10378292
Sodium Hydroxide Pellets	Fisher Scientific Cat. No. S318-500
Sodium Hydroxide, 1.0N (liquid)	LabChem, Inc. Cat. No. 1310-73-2

4.2 Reagent Preparation and Storage

5% Diluted Sodium Hypochlorite (Bleach) - For use on Novus ONLY	
Preparation	Make a 5% diluted Bleach solution: The concentrated Clorox Bleach has 8.25% sodium hydroxide. Add 3 mL Reagent Grade Water to 3 mL Clorox Bleach to achieve a dilution of approximately 4%.
Storage	Store at 15-30°C
Stability	Stable for 1 day from date prepared.

Rinse Solution	
Preparation	Pull the probe out of the Rinse Solution bottle and place the probe on a clean piece of gauze. Pour out any leftover Rinse Solution into the sink. First, add 1000 mL of Reagent Grade Water to the container, and then add 2 mL of Rinse Additive. Place the cap back on the bottle, use two fingers to block the two holes, and gently invert the bottle back and forth twice without making any bubbles.
Storage	Store at 15-30°C
Stability	Stable for 14 days

Clinitek Novus® 10 Cassette	
Preparation	Ready for use, no additional preparation is required.
Storage	Store at 15-30°C. DO NOT REFRIGERATE.
Stability	Use within 14 days after installation in instrument.
Special Handling	Do not open or puncture the foil seal until ready to use. Do not use test cards that might fall out of the cassette. Dispose of them. To ensure that cards do not fall out of the cassette, open the cassette and immediately load it into the system. Do not move the cassette or flip it upside down. See Addendum 6.

Reagent Grade Water	
Preparation	Ready for use, no additional preparation is required.
Storage	Store at 15-30°C.
Stability	Bottled water expires 30 days after opening.

UF II Sheath	
Preparation	Ready for use, no additional preparation is required.
Storage	Store at 2-35°C.
Stability	Open stability 60 days.

UF II Pack-BAC	
Preparation	Ready for use, no additional preparation is required.
Storage	Store at 2-35°C. Contains acidic solvent.
Stability	Open stability 60 days.

UF II Pack-SED	
Preparation	Ready for use, no additional preparation is required.
Storage	Store at 2-35°C.
Stability	Open stability 60 days.

UFII Search-BAC (stain solution)	
UFII Search-SED (stain solution)	
Preparation	Ready for use, no additional preparation is required.
Storage	Store at 2-35°C
Stability	Open stability 60 days

Sodium Hydroxide (NaOH) Pellets	
Preparation	Ready for use, no additional preparation is required.
Storage	Store at 2-35°C.
Stability	Remains stable until the expiration date shown on the bottle

Sodium Hydroxide (NaOH) 1.0N	
Preparation	Ready for use, no additional preparation is required.
Storage	Store at 5-30°C. Keep away from strong acids, metals, metal powders, and source of ignition or direct sunlight.
Stability	Remains stable until the expiration date shown on the bottle

5. CALIBRATORS/STANDARDS

5.1 Calibrators/Standards Used

Calibrator	Supplier and Catalog Number
Clinitek Novus® Calibration Kit	Siemens Healthcare, Cat. No. 10697753

5.2 Calibrator Preparation and Storage

NOTE: Date and initial all calibrators upon opening. Each container must be labeled with (1) substance name, (2) lot number, (3) date of preparation, (4) expiration date, (5) any special storage instructions; check for visible signs of degradation. When placed onboard the analyzer, the instrument captures the date / time loaded and calculates and tracks the opened expiration.

Calibrator	Clinitek Novus® Calibration Kit
Preparation	Supplied ready for use, no preparation is required.
Storage/Stability	<ul style="list-style-type: none"> Store tightly capped at 2-8°C Stable until the expiration date shown on the bottle label when stored at 2-8°C.

5.3 Calibration Procedure

Criteria	Special Notations	
Frequency	Clinitek Novus: Every time a new reagent cassette is loaded on the instrument. (See Addendum 6 for instructions) UF1000i: Calibration is performed as part of the quarterly PM scheduled by the FSE (Field Service Engineer) and should be requested: <ul style="list-style-type: none"> When any critical instrument component is replaced When multiple levels of commercial controls consistently fall outside established acceptable limits 	
Tolerance Limits	IF: Results fall within the assay specific guidelines and the calibration status displayed is "acceptable" and QC values are within acceptable limits:	THEN: Proceed with analysis.
	Calibration status is displayed as failed, or the QC values are outside acceptable limits:	Troubleshoot the assay. Refer to instrument operation manual for specific calibration trouble-shooting help. Repeat calibration and controls after problem is corrected. Document appropriately.

Step	Procedure - Clinitek Novus®
1.	Aliquot at least 3 mL of 5.25% Sodium Hypochlorite into a 16 X 100 mm round bottom glass tube. Gently mix each bottle of calibrator and aliquot at least 3 mL of calibrators 1, 2, 3 and 4 into tubes labeled 1, 2, 3, and 4 respectively. Immediately recap calibrator bottles and return to the refrigerator. Note: Do not mix Calibrator Kits or lot numbers. If a Calibrator Kit is low on one level, throw away the entire set and start with a new kit.
2.	Allow calibrator tubes to reach room temperature. Gently mix each tube immediately before using.
3.	Calibrators do not have their own dedicated rack. Use any specimen rack and load as described below: Position 1: 5.25% diluted Bleach Position 2: Calibrator 4 Position 3: Calibrator 1 Position 4: Calibrator 2 Position 5: Calibrator 3
4.	Select: System > Calibration
5.	Check lot numbers on display screen against the lot number on the bottles. If you want to change the lot, go to step 6. If you want to add new lots, go to step
6.	Select Next > Start
7.	After they system moves the rack to the left side of the rack handler, remove the rack.

Note: If probe has been replaced carryover studies should be performed. Only one parameter needs to be chosen for the carryover studies.

6. QUALITY CONTROL

6.1 Controls Used

Controls	Supplier and Catalog Number
Clinitek Atlas Positive Control Strips	Siemens Healthcare Cat. No. 10311124
Clinitek Atlas Negative Control Strips	Siemens Healthcare Cat. No. 10311135
UF II Control – H & UF II Control - L	Siemens Healthcare Cat. No. 10378295

6.2 Control Preparation and Storage

Control	Clinitek Atlas Positive and Negative Control Strips
Preparation	<ul style="list-style-type: none"> Place 12 mL of Reagent Grade Water in an appropriately labeled specimen tube. Remove Clinitek Atlas Control Strip from the bottle and replace the cap immediately. Place the strip into the tube. Cap tightly. Gently invert the tube back and forth for 2 minutes.

	<ul style="list-style-type: none"> Allow tubes to stand for 30 minutes at room temperature. Invert several more times, then remove and discard the strips.
Storage/Stability	Store strips in the original bottle (tightly capped) at 15 – 30°C. Reconstituted QC remains for 3 hours at room temperature. Do not store the bottle in direct sunlight. Do not remove the desiccant from bottle. The strips are stable until the expiration date shown on the bottle.

Control	UF II Controls
Preparation	Supplied ready for use, no preparation is required.
Storage/Stability	Store at 2-10°C. Open vial stability is 30 days at 2-10°C if vials are promptly capped and returned to refrigerator after use.

6.3 Frequency

Step	Action
1.	Quality Control testing is performed once per shift on both Clinitek Novus and UF1000i modules. The urine chemistry controls and macroscopic controls must be run simultaneously.
2.	The positive control must be run prior to the negative control to verify carry over has not occurred.
3.	Whenever new QC product or strips are received, parallel testing between the old shipment / lot number and the new shipment / lot number will be done to assure that it is working properly.
4.	QC is performed after major preventive maintenance or change of a critical instrument component or software changes.
5.	All control levels must be tested after calibration or major servicing of the instruments.

6.4 Tolerance Limits and Criteria for Acceptable QC

Step	Action
1	Values obtained should fall within the range. Both Clinitek Novus and UF1000i flag any outliers.
2	Run Rejection Criteria <ul style="list-style-type: none"> Anytime results exceed the established parameters, the run is considered out of control (failed) and patient results must not be reported. The technologist must follow the procedure in the Laboratory QC Program to resolve the problem. Nine (9) hours after initial QC run, the QC will timeout on the instrument and hold all patient results until another QC run is performed.

Step	Action
3	<p>Corrective Action:</p> <ul style="list-style-type: none"> All rejected runs must be addressed through corrective action. Steps / actions taken in response to QC failures must be documented. Patient samples in failed analytical runs must be <u>reanalyzed according to the Laboratory QC Program</u>. Supervisors may override rejection of partial or complete runs only with detailed documentation and criteria for overrides that are approved by the Medical Director. Consult and follow corrective action guidelines in Laboratory QC Program.

6.5 Documentation

- Document all QC results (in range and out of range) and resolutions in Unity for Novus or on the UF-1000i Maintenance log. Refer to addendum 5 for Unity steps.
- QC tolerance limits are programmed into the instrument and Data Innovations.
- Quality control records are reviewed weekly by the Group Lead or designee and monthly by the Supervisor/Manager or designee.
- Refer to complete policies and procedures for QC documentation and for record retention requirements in the Laboratory QC Program

6.6 Quality Assurance Program

- Each new lot number of reagent or new shipment of the same lot of reagent must be tested with external control materials and previously analyzed samples. Performance of the new lot must be equivalent to the previous lot, utilize published TEA for acceptability criteria.
- Training must be successfully completed and documented prior to performing this test. This procedure must be incorporated into the departmental competency assessment program.
- The laboratory participates in CAP proficiency testing. All proficiency testing materials must be treated in the same manner as patient samples.
- Monthly QC must be presented to the Medical Director or designee for review and signature.
- Consult the Laboratory QC Program for complete details.

7. EQUIPMENT and SUPPLIES

7.1 Assay Platform

Siemens Clinitek AUWi composed of Clinitek Novus and UF1000i

7.2 Equipment for manual method

- Bright field microscope equipped with Low Power (10x) and High Power (40X) Objectives.
- Single plain glass microscope slides 22x22 mm and cover slips for manual method.
- Centrifuge

8. PROCEDURE

NOTE: For all procedures involving specimens, buttoned lab coats, gloves, and face protection are required minimum personal protective equipment. Report all accidents to your supervisor.

8.1 Instrument Set-up Protocol

For Maintenance, refer to **Addendum 1**

A	Control Analysis, Clinitek Novus
1.	Use any specimen rack to load the positive and negative QC prepared from section 6.2. Label the positive and negative QC with the corresponding barcodes. (QC01 = POS and QC02 = NEG) NOTE: Positive QC = Position 1 and Negative QC = Position 2
2.	Place the rack on the right side of the rack handler with the open side of each tube slot facing the system. On the AUV track for the UF, press “Menu”, then “1. Through Mode”. This will allow the Novus QC to bypass the UF 1000i analysis. Press Start on the track.
3.	QC results are printed from Novus and must be manually entered into Unity. Ensure all QC passes within the acceptable range before testing patients. Refer to Addendum 5 <i>Novus QC Processing in Unity</i> . On the AUV track for the UF1000i, press “Menu”, then “1. Through Mode”. This will enable the UF1000i to sample and analyze patient specimens.

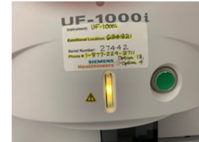
B	Control Analysis, UF1000i
1.	Remove the bottles of UFII CONTROL (low and high) from the refrigerator, and equilibrate to room temperature (15-30 C) for 30 minutes before use.
2.	Ensure the instrument is ready by pressing the green button on the front of the analyzer. The LED will be yellow in a non-ready state.  Once the instrument is ready, the LED will be solid green. (the instrument will go into sleep mode if it is idle more than 15 minutes)

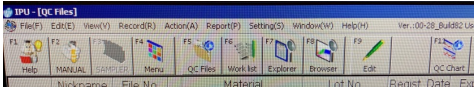
B	Control Analysis, UF1000i
3.	<p>Double-click on the IPU icon on the desktop. <i>username: uf</i> <i>leave the password blank</i> This will bring up the IPU Menu. Click on “MANUAL” button on the tool bar on the menu screen.</p>  <p>This will bring up the Manual Sample No. screen. Click on the QC button.</p> <ul style="list-style-type: none"> The QC Analysis-UF-1000i screen will display. Listed will be the QC material listed by lot number. Select the desired QC file line that is to go under quality control analysis from the file list displayed on the QC Files screen and click OK. A screen automatically opens with directions to prepare the QC. Click Close after reading the instructions. You are now ready to prepare the QC for analysis.
4.	<p>Shake a bottle of the UFII CONTROL-L a few times until there is no particle sediment at the bottom, then shake it vigorously another 20 times. Note: Use UFII CONTROL immediately after mixing. The particles settle at the bottom of the bottle if left to stand more than 30 seconds, which leads to an uneven particle distribution and thus a measurement error.</p>
5.	<p>Immediately (within 10 seconds) after mixing, press the side of the bottle gently to allow 0.9 mL (18-23 drops) of the reagent to drop from the tip nozzle into the Dimension Vista SSC cup. Immediately insert the aspiration pipette into the SSC cup and make sure that a proper aspiration is possible. Then press the start switch (green button on the front of the instrument).</p>
6.	<p>Discard the cup after measurement. Note: Any cup used in this measurement must not be reused.</p>
7.	<p>After the QC is completed, select Accept. Do not select re-analyze.</p>
8.	<p>Repeat with UFII CONTROL-H</p>
9.	<p>To view the QC, click on the QC files icon. Double-click on the QC you wish to view and it will bring you to the LJ page. Ensure all QC passes in the IPU (within acceptable limits) before testing patients. Document review on the UF-1000i Maintenance Log.</p>

8.2 Disposing UF1000i Waste

The waste from UF1000i instrument has a pH 3; it must be neutralized (pH 7) before it is poured down the drain.

UF1000i Waste	
1.	Empty the waste daily when container is approximately half-full (performed by night shift) . Record on UF Maintenance log.
2.	Make sure the instrument is not in use and it is in a Standby mode.
3.	a. Pour 2-3 capfuls of NaOH pellets into the waste container and mix until there is a color change. OR b. Add 75mL of liquid NaOH to approximately 10L of waste (half-full container).
4.	Flush drain with copious amount of water.

8.3 Test Run

Routine Testing: AUWi	
1.	Make sure AUW track is turned ON . Both sides of the analyzer (Novus and UF1000i) display READY .
2.	Load samples into racks, aligning barcodes toward the open side of the rack. Notes: <ul style="list-style-type: none"> Sort out low volume samples (less than 2mL), grossly bloody, mucoid or highly pigmented urines. Test these samples using the backup method (see Urinalysis Clinitek 500 and Microscopic Examination of Urine, Manual Method procedures). Samples >2mL but <4mL cannot be run on the AUW track and must be loaded manually. See “Short Sample Testing – Novus and UF 1000i” (section 8.4).
3.	Mix specimens well by inversion and uncap directly before loading.
4.	Press START on the AUW track to begin processing samples.
5.	The Novus will pipette a small amount of specimen and dispense onto reagent pad at a specific time cycle and also dispense an appropriate amount in the specific gravity well to perform specific gravity.
6.	Barcode read errors will default to TEST and will appear as {UNKNOWN} on the workload. Storage position will be assigned.
7.	Racks will automatically be transported to the UF1000i™. If the UF is in sleep status, it will be awakened by the track before transferring racks to the measurement lane.
8.	UF1000i is bidirectional and queries LIS for orders on matched barcodes. Only those accessions requiring a microscopic analysis will be mixed and tested. (see Section 10: Procedure Notes for triggers for microscopic reflex). Barcode read errors will be defaulted to SKIP.
9.	Pull samples requiring a manual microscopic review as indicated on the repeat list (see Addendum 3 <i>UF1000i Review Criteria</i>)

8.4 Short Sample Testing

Short Sample Testing, Clinitek Novus	
1.	Mix specimens well by inversion and uncap directly before loading.

Short Sample Testing, Clinitek Novus	
2.	Place the specimen in the STAT Holder , then push it forward until it stops moving.
3.	On the Conveying System, select 1 “STAT”
4.	After sample aspiration and processing is done, press the “Sample ID” tab to enter patient ID information (Do not press the highlighted yellow area, press the Sample ID).
5.	Press Enter , then press Done .
6.	Press the “Push Button” to release the STAT Holder to its home position.
7.	Triage samples needing microscopic testing (based on reflex criteria – Section 10) to the UF1000i.

Short Sample Testing, UF1000i	
1.	Make sure the instrument is in the Ready mode, meaning the solid green light is ON. If the light is green and flashing, it means the instrument is in the sleep mode. Press the Start button to initialize the system.
2.	From the main menu, select Manual (F2) .
3.	Enter patient ID information, and then press OK .
4.	Mix specimens well by inversion and uncap directly before loading.
5.	Place the tube in the Aspiration Port, and then press Start .
6.	Pull samples requiring a manual microscopic review as indicated on the repeat list (see Addendum 3 <i>UF1000i Review Criteria</i>)

8.5 Microscopic Exam

Specimen Preparation for Microscopic Exam	
1.	Centrifuge specimens pulled for manual microscopic review for 5 minutes at 1600 RPMs.
2.	Decant the supernatant leaving roughly 0.5 mL.
3.	Re-suspend urine sediment completely prior to microscopic exam.
4.	When performing a microscopic examination, both low and high power must be used. <ul style="list-style-type: none"> • Scan the slide (minimum of 10 fields) on low power to determine general composition of sediment. Quantitate any squamous epithelial cells, casts, or mucus if present. • Examine a minimum of 10 fields on high power to determine the presence and quantify the number of WBCs, RBCs, bacteria and other microscopic constituents. • Identify and classify each type of cast, epithelial cell and crystal. • Always report results for WBC, RBC, Epithelial cells, Bacteria and Hyaline Casts to maintain consistency in reporting.
5.	When performing a microscopic review, scan the slide to verify the compatibilities and review flags. Confirm or edit color and UF1000i results appropriately. Refer to Section 10 for reporting guidelines.

8.6 Replacement of reagent / supplies

If a reagent runs low during analysis, the instrument stops automatically after completing the last analysis and the appropriate error message displays on the help dialog box. Replace only the indicated reagent with the new reagent. Example: *UFII SEARCH-BAC Empty Error*

NOTE: **Handle reagent gently to avoid bubbling. Never shake the reagent.** Do not use reagent right after moving it.

Specimen Preparation for Microscopic Exam	
1.	When the UF-1000i runs out of a reagent, an alarm sounds and the instrument stops after completing analysis of the sample being processed.
2.	A message indicating which reagent requires replacement is displayed in the “Help” dialog box. Click OK.
3.	The Reagent Replacement dialog box will display.
4.	Select the tab for the reagent being replaced. Enter the reagent lot information by using the handheld barcode reader, scan the barcode on the container. Use the barcode reader to scan the lot number into the reagent replacement dialog box. Check the updated the expiration date and adjust as needed. (The expiration date will default to 60 days from the date in which it is loaded on the UF1000i to capture the opened stability.)
5.	Remove the cap from the new container.
6.	Remove cap and tubing from empty container and using clean technique, insert the tubing into the new container.
7.	Click RUN in the dialog box to begin priming the reagent.
8.	Dispose of empty containers according to local regulations.

When changing sheath / diluent on the UF1000i, you must select run for the new constituent to prime.
 ****Perform background checks only when changing sheath and diluents.

9. CALCULATIONS

Not applicable

10. REPORTING RESULTS AND REPEAT CRITERIA

10.1 Interpretation of Data

Macroscopic Analysis

Analyte	Normal	Novus Value	Report As	LIS Code
Color	Yellow	Yellow	Yellow	YEL
		Dark Yellow	Dark Yellow	DYEL
		Orange	Orange	ORNG
		Blue	Blue	BLUE
		Red	Red	RED
		Other	* Specify Color	*See Addendum 2
Clarity	Clear	Clear	Clear	CLER
		Cloudy	Cloudy	CLDY
		Turbid	Turbid	TUR
Glucose	Negative	Negative	Negative	NEG
		100 mg/dL	1+	1+
		250 mg/dL	2+	2+
		500 mg/dL	3+	3+
		≥1000 mg/dL	4+	4+
Protein	Negative	Negative	Negative	NEG
		10-20 mg/dL	Trace	TR
		30 mg/dL	1+	1+
		100 mg/dL	2+	2+
		300 mg/dL	3+	3+
Bilirubin	Negative	Negative	Negative	NEG
		Small	1+	1+
		Moderate	2+	2+
		Large	3+	3+
Urobilinogen	0.2 EU/dL	0.2 EU/dL	0.2 EU/dL	0.2 EU/dL
		1.0 EU/dL	1.0 EU/dL	1.0 EU/dL
		2.0 EU/dL	2.0 EU/dL	2.0 EU/dL
		4.0 EU/dL	4.0 EU/dL	4.0 EU/dL
		≥ 8.0 EU/dL	≥ 8.0 EU/dL	≥ 8.0 EU/dL
Blood	Negative	Negative	Negative	NEG
		Trace	Trace	TR
		Small	1+	1+
		Moderate	2+	2+
		Large	3+	3+
Ketone	Negative	Negative	Negative	NEG
		Trace	Trace	TR
		15 mg/dL	1+	1+
		40 mg/dL	2+	2+
		80 mg/dL	3+	3+
		≥ 160 mg/dL	4+	4+

Analyte	Normal	Novus Value	Report As	LIS Code
Leukocyte Esterase	Negative	Negative	Negative	NEG
		Trace	Trace	TR
		Small	1+	1+
		Moderate	2+	2+
		Large	3+	3+
pH	pH values range from 5.0 – 9.0, reported in increments of 0.5.			
Specific Gravity	Specific Gravity measures from 1.000 – 1.030			
Nitrite	Positive or Negative			

Microscopic Analysis

Power Field Instructions for Microscopy	
High Power Field (HPF)	Low Power Field (LPF)
RBCs and WBCs	Squamous Epithelial Cells
Renal & Transitional Epithelial Cells	All Casts
Bacteria / Yeast / Crystals	Mucus

Test	# seen	LIS translation
WBC (average # / HPF)	0 - 2	O0
	3-5	O3
	6-10	O6
	11-20	O11
	21-100	O21
	>100	TNTC
RBC (average # / HPF)	0 - 2	O0
	3-5	O3
	6-10	O6
	11-20	O11
	21-100	O21
	>100	TNTC
Epithelial (average # / LPF)	0 - 2	Rare
	3-5	Occasional
	6-10	1+
	11-20	2+
	21-100	3+
	> 100	4+
Casts (average # / LPF)	0-1	O1
	2-5	O2
	6-10	O6
	11-20	O11
	21-100	O21
	TNTC	TNTC

Test	# seen	LIS translation
Bacteria / HPF	None seen	Negative
	Few	1+
	Small	2+
	Moderate	3+
	Large	4+
	Packed	TNTC

Only report these analytes if seen during microscopic review:

Test	# seen	LIS translation
Transitional Epithelial Cells (average # / HPF)	0 - 2	Rare
	3-5	Occasional
	6-10	1+
	11-20	2+
	21-100	3+
	> 100	4+
Renal Epithelial Cells (average # / HPF)	0 - 2	Rare
	3-5	Occasional
	6-10	1+
	11-20	2+
	21-100	3+
	> 100	4+
Crystals (average # / HPF)	0-5	Few
	6-10	1+
	11-20	2+
	>21	3+
Mucus / LPF	Occasional	Occasional
	Small	1+
	Moderate	2+
	Large	3+
	Packed	4+
Yeast / HPF	Occasional	Occasional
	Small	1+
	Moderate	2+
	Large	3+
	Packed	4+
Trichomonas	No quantitation – report “present” if seen	
Enterobius Vermicularis	No quantitation – report “present” if seen. Consult with pathologist prior to releasing results.	
Schistoma Haematobium	No quantitation – report “present” if seen. Consult with pathologist prior to releasing results.	
Oval Fat Bodies	No quantitation – report “present” if seen	

If the report flags for...	Then...
X'TAL (Crystals)	Check for the presence of Crystals, do not report Amorphous Crystals
YLC (Yeast Like Cells)	Check for the presence of Yeast
SRC (Small Round Cells)	Check for the presence of Transitional or Renal cells
Path. CAST (Pathological Casts)	Check for the presence of Casts
MUCUS	Check for the presence of Mucus
SPERM	Do not report Sperm on any patients.
Cond. (Conductivity)	This is not part of the microscopic analysis. The service engineer uses this information for troubleshooting.

10.2 Rounding

Not applicable

10.3 Units of Measure

Refer to section 10.1

10.4 Analytical Measurement Range (AMR)

Platform	Analyte	Linear Range
Clinitek Novus® Sysmex UF1000i™	Specific Gravity	1.000 - 1.030
	WBC	0- 5,000/μL
	RBC	0- 5,000/μL
	Epithelial Cells	0 - 200/μL
	Casts	0.00- 30.00/μL
	Bacteria	0 - 10,000/μL

Macroscopic Parameters			
Analyte	Reportable Range	Analyte	Reportable Range
PH	5.0 – ≥ 9.0	Occult Blood	Neg – 3+
Specific Gravity	1.000-1.030	Protein	Neg – 4+
Glucose	Neg – 4+	Nitrite	Neg or Positive
Bilirubin	Neg – 3+	Leukocyte Esterase	Neg – 3+
Ketones	Neg – 4+	Urobilinogen	0.2 - >8.0 EU/dL

Microscopic Parameters	
WBC	0 - >100/HPF
RBC	0 - >100/HPF
Bacteria	NEG – TNTC
Epithelial Cells	NEG – 4+
Casts	0 - >100/LPF
Mucus	NEG – 4+ / LPF
Crystals	NEG – 3+ / HPF

Microscopic Parameters	
Yeast	NEG – 4+ / HPF
Oval Fat Body and Urine Parasites	Present / not Present

10.5 Review Patient Data

- Review patient results for unusual patterns, trends or distribution.
- Report atypical or unexpected results or trends for this test to appropriate supervisory personnel, prior to releasing results.

10.6 Repeat Criteria and Resulting

- Results from the Novus and the UF1000i transmit to the LIS automatically.
- WBC, RBC, Epithelial Cells, Bacteria and Hyaline Casts are reported on every specimen.
- UF1000i results are converted from #/uL to #/hpf or #/lpf by the LIS.
- For parameters which require microscopic review, results are entered manually on a keyboard, see Addendum 2.

Test	If the result is...	Then...
Bilirubin	1+, 2+ and 3+	The comment “Presumptive positive bilirubin. Consider confirmation by serum bilirubin if clinically indicated.” will be appended to the result by the LIS.
pH	> 9.0	Remove urine protein and urine glucose result and replace with the English text code UAMPG UAMUP . The code translates to “Unable to accurately measure urine protein or glucose when pH is >9.0”

11. EXPECTED VALUES

11.1 Reference Ranges

Macroscopic	
Color	Yellow
Appearance	Clear
pH	5.0 – 9.0
Specific Gravity	1.005 – 1.030
Glucose	Negative
Bilirubin	Negative
Ketones	Negative
Occult Blood	Negative

Macroscopic	
Protein	Negative
Nitrite	Negative
Leukocyte Esterase	Negative
Urobilinogen	0.2 EU/dL

Microscopic	
WBC	0-2/HPF
RBC	0-2/HPF
SEP (Squamous Epithelial)	0-2/LPF
TEP (Transitional Epithelial)	0/HPF
REP (Renal Epithelial)	0/HPF
BACT	Negative
Yeast	Negative /HPF
Trichomonas	Negative /HPF
Hyaline Casts	0-1/LPF
All other Casts	0/LPF
Crystals	None seen /HPF
Mucus	0/LPF

11.2 Critical Values

None established

11.3 Standard Required Messages

None established

12. CLINICAL SIGNIFICANCE

Urinalysis, as part of a routine patient exam, has assisted in the diagnosis and monitoring of many diseases, such as renal disease, diabetes mellitus and liver disease.

Highly abnormal/unusual urinalysis results should be brought to the attention of the supervisor or designated experienced technologist or pathologist.

Chart of Significant Observations and their Associated Disorders

Test	Disorder	Observation
Color	Homogentisic acid Melanuria Indicanuria Porphyrinuria	Black Black Dark blue Port wine

Test	Disorder	Observation
Casts	Renal disease	Waxy casts, RBC casts
Crystals	Tyrosyluria Cystinuria	Sheaths of fine needles Colorless hexagonal plates

12.1 Cells

Erythrocytes:

Smooth biconcave disks approximately 7u in diameter and 2u thick, pale or yellowish appearance. In alkaline or hypotonic urine, the red cells swell and can lyse. Lysed cells, “ghost cells”, are faint, colorless circles and are actually empty red cell membranes. In hypertonic urine, red cells will crenate. Swollen and crenated RBC’s are sometimes mistaken for WBC’s.

The presence of a positive test for occult blood is often helpful. Red cells are refractile and when the fine adjustment is turned up or down so the red cells are on a different plane, red cells appear as black circles.

Normally RBC’s do not appear in urine, although a few are not considered abnormal.

In females, the presence of red cells can be a result of menstrual contamination.

Injury or rupture of blood vessels of the kidney or urinary tract will release red cells into the urine. Hematuria will also occur in cases of internal bleeding.

Leukocytes:

White blood cells are usually spherical and can appear as dull gray or a greenish yellow color. They may occur singly or in clumps and usually can be identified by their granules or lobes of their nucleus. WBC’s shrink in hypertonic urine, and swell up or are rapidly lysed in hypotonic or alkaline urine. Granules in swollen cells may demonstrate Brownian movement. These cells are referred to as “glitter cells”. An increase in WBC’s in the urine is associated with an inflammatory process in or adjacent to the urinary tract.

Epithelial Cells:

Squamous epithelial cells are easily recognized as large, flat, irregularly shaped cells, which contain a small central nucleus and abundant cytoplasm.

Renal tubular epithelial cells are slightly larger than leukocytes and contain a large, round nucleus. They may be flat, cuboidal or columnar.

Transitional epithelial cells are two to four times as large as white cells. They may be round, pear-shaped or may have a tail-like projection.

Normally, a few epithelial cells are found in the urine as a result of the normal sloughing off of old cells. A marked increase indicates an inflammation of that portion of the urinary tract from the cells derived. Squamous epithelial cells occur principally in the urethra and vagina, renal tubulars in the renal tubules and transitional cells in the urinary tract from the pelvis of the kidney to the upper portion of the urethra.

12.2 Crystals - Commonly Found in Acid Urine

Uric Acid: Uric acid crystals occur in many different shapes, but the most characteristic forms are the diamond or rhomboid prism and the rosette, which consists of many crystals clustered together. They may occasionally have six sides and this form is sometimes erroneously identified as cystine. Uric acid crystals are usually stained with urinary pigments and can therefore be yellow or reddish-brown in color. Under polarized light, uric acid crystals will take on a variety of colors. The presence of uric acid crystals can be normal. Pathological conditions in which uric acid crystal in urine are found include gout, high purine metabolism, acute febrile conditions, chronic nephritis and Lesch-Nyhan syndrome.

Calcium Oxalate: Colorless octahedral or “envelope” shaped crystals, which look like small squares crossed by intersecting diagonal lines. They rarely appear as oval spheres or biconcave disks when viewed from the side. When focusing on the typical calcium oxalate crystal, the “X” of the crystal will be very prominent. They are frequently found in acid urine, but occasionally can be found in alkaline urine. Calcium oxalate crystals can be present normally in the urine after ingestion of various oxalate-rich foods. Increased amounts of calcium oxalate crystals suggest conditions such as oxalate calculi, ethylene glycol poisoning, diabetes mellitus, liver disease, severe chronic renal disease, and intake of large doses of Vitamin C.

Hippuric Acid: Yellow-brown or colorless elongated prisms or plates. They may be so thin as to resemble needles and often cluster together. These crystals are rarely seen in the urine and have practically no clinical significance.

Sodium Urate: Colorless or yellowish slender prisms (not pointed at the ends) occurring in sheaves or clusters. They have no clinical significance.

Calcium Sulfate: Long, thin, colorless needles or prisms that are extremely soluble in acetic acid. These crystals are rarely seen in the urine and have no clinical significance.

Cystine: Colorless, refractile, hexagonal plates with equal on unequal side appearing singly, on top of each other or in clusters. They frequently have a laminated appearance. The presence of cystine crystals in the urine is always important. They occur in patients with congenital cystinosis, congenital cystinuria, and they can form calculi.

Leucine: Oily, highly refractile, yellow or brown spheroids with radial and concentric striations. These crystals are found in urine of patients with maple syrup urine disease, Oasthouse urine disease, and in serious liver disease. Leucine and tyrosine crystals are frequently present together in serious liver disease.

Tyrosine: Very fine, highly refractile needles occurring in sheaves or clusters. These crystals occur in serious liver disease, tyrosinosis and Oasthouse urine disease.

Cholesterol: Large, flat transparent plates with notched corners, exhibiting a variety of colors under polarized light. At times, cholesterol crystals are found as a film on the surface of the urine instead of in the sediment. The presence of cholesterol crystals in urine indicates excessive tissue breakdown. They may also be present in chyluria, which is the result of either thoracic or abdominal obstruction to lymph drainage.

Sulfa and other drug crystals: Sulfonamide drugs precipitate out as sheaves of needles, usually with eccentric binding, that are clear or brown in color. They are soluble in acetone and can be verified by a lignin test. Radiograph dyes can crystallize out as pleomorphic needles, which can occur singly or in sheaves, occasionally seen with brown spheres, and is birefringent under polarized light. These dyes are very dense and will result in an elevated specific gravity. Bilirubin may crystallize out as red or reddish-brown needles or granules. They are soluble in chloroform, acetone, acid, and alkali, but are insoluble in alcohol, and ether.

12.3 Crystals – Commonly Found in Alkaline Urine

Triple Phosphate: Colorless prisms with three to six sides which frequently have oblique ends. They may precipitate in feathery or fern-like crystals. They may be found in normal urine or in pathological conditions, including chronic pyelitis, chronic cystitis, enlarged prostate and when urine is retained in the bladder.

Calcium Carbonate: Small, colorless crystals appearing in dumbbell or spherical forms, or in large granular masses. They are larger than amorphous and, when in clumps, they appear to have a dark color. They have no clinical significance.

Calcium Phosphate: Long, thin, colorless prisms with one pointed end, arranged as rosettes or stars, or appearing as needles. They may also form irregular, granular plates, which float on the surface of the urine. They may be present in normal urine, but they may also form calculi.

Ammonium Biurate: Yellow-brown spherical bodies with long, irregular spicules often described as “thorn apples”. They may also occur as yellow-brown spheroids without spicules, although this form is not common. Occasionally, they are found in acid urine. They are abnormal only in freshly voided urine.

12.4 Casts

Urinary casts are formed in the lumen of the tubules of the kidney. They can form as a result of the precipitation or gelation of Tamm-Horsfall mucoprotein, the clumping of cells or other material within a protein matrix, the adherence of cells or material to the matrix or by conglutination of material within the lumen. Factors involved in cast formation include urinary stasis, increased acidity, high solute concentration, and the presence of abnormal ionic or protein constituents.

Cast formation usually takes place in the distal and collecting tubules. Casts will dissolve in alkaline urine. They have nearly parallel sides and rounded or blunted ends, and they vary in size and shape according to the tubules in which they were formed. They may be convoluted, straight or curved, and vary in length. Casts are always renal in origin, and they are important indicators of intrinsic renal disease.

Hyaline - Colorless, homogenous, transparent casts composed of gelled Tamm-Horsfall protein usually found with rounded ends. They have a low refractive index and must be viewed under low light. They may contain some inclusions, which were incorporated while in the kidney. A few hyaline casts may be found in normal urine and increased amounts are frequently present following physical exercise and physiologic dehydration.

Red Cell - May contain only a few RBC's in a protein matrix or there may be many cells packed close together with no visible matrix. If the RBC's are still intact, the cast is termed a red cell cast. If the cast has degenerated to a reddish-brown granular cast, then it is termed a hemoglobin or blood cast. Red cell casts mean renal hematuria and are always pathologic. They are usually diagnostic of glomerular disease caused by acute glomerulonephritis, lupus nephritis, Good Pasture's Syndrome, SBE, and renal trauma. They can also be present in renal infraction, severe pyelonephritis, right-sided congestive heart failure, renal valve thrombosis, and periarteritis nodosa.

White Blood Cell- May contain a few WBC's or many white cells tightly packed together. The majority of white cells are PMN's. If the cells are intact, the nuclei may be clearly visible, but, as they degenerate, the cell membranes disappear and the cast becomes granular. White cell casts are present in renal infection and non-infectious inflammation.

Granular - May be the results of degeneration of cellular cast, or they may represent the direct aggregate of serum proteins into a matrix of Tamm-Horsfall mucoprotein. Finely granular casts contain fine granules, gray or pale yellow in color. Coarsely granular casts contain larger granules that are darker in color, often giving the cast a black color. Granular casts almost always indicate a significant renal disease, although they may present for a short time following strenuous exercise.

Epithelial - Epithelial cells may be arranged in parallel rows or haphazardly. They may vary in size, shape, or stage of degeneration. Epithelial casts may form as a result of stasis and the desquamation of renal tubular epithelial cells. They occur after exposure to nephrotoxic agents or viruses (CMV, hepatitis), in severe chronic renal disease, and in the rejection of a kidney allograft.

Waxy - Waxy casts have a very high refractive index, are yellow, gray or colorless, and have a smooth, homogeneous appearance. They frequently occur as short broad casts with blunt or broken ends, and often have cracked edges. They may result from the degeneration of granular casts. Conditions in which waxy casts are found include severe

chronic renal failure, malignant hypertension, renal amyloidosis, and diabetic nephropathy.

Fatty - Casts that have incorporated free fat droplets or oval fat bodies. Fatty casts are seen when there is fatty degeneration of the tubular epithelium.

12.5 Miscellaneous Structures

Bacteria - The presence of bacteria is easily recognized under high power. The presence of large numbers of bacteria in freshly voided urine is usually indicative of a urinary tract infection.

Yeast - Smooth, colorless, usually ovoid cells with doubly refractive walls. They can vary in size and often show budding. They are insoluble in acid and alkali. Yeast may be found in urinary tract infections or as a result of skin contamination.

Spermatozoa - Oval bodies with long, thin, delicate tails. They may be present in males after epileptic convulsions, nocturnal emissions, diseases of the genital organ, and in spermatorrhea. Spermatozoa in males or adult females is **NOT** reported.

Mucus Threads - Long, thin wavy threads of ribbon-like structures that may show faint longitudinal striations. They are present in normal urine in small numbers, but they may be abundant in the presence of inflammation or irritation of the urinary tract.

Oval Fat Bodies and free Fat Droplets - Highly refractile globules, frequently yellow-brown in appearance. Oval fat bodies are usually defined as renal tubular cells containing fat droplets. Oval Fat bodies exhibit the Maltese Cross phenomenon when viewed with polarized light. Fat may be present in the urine as a result of fatty degeneration of the tubules, in nephrotic syndrome, diabetes, eclampsia, renal poisoning, fractures of the long bones, and injuries crushing the subcutaneous fat.

12.6 Parasites

Trichomonas vaginalis - Flagellated organism about the size of a leukocyte. It should not be reported unless it is mobile. It is frequently accompanied by the presence of WBC's and epithelial cells.

Enterobius vermicularis- Pinworm ova and, occasionally, the female adult. Very characteristic in shape, having one flat and one rounded side.

Schistosoma haematobium- These eggs have a light yellowish-brown transparent shell with a distinct terminal spine. The eggs measure between 112 to 170 mm by 40 to 70 mm.

12.7 Artifacts

Starch - Irregularly shaped, round or oval, highly refractive bodies that appear to exhibit the "Maltese Cross" phenomenon under polarized light. These are distinguished from

Oval Fat bodies in that they are irregular in shape and are larger in size, being several times larger than an RBC. Most commonly due to contamination with powder.

Fibers - Long and flat threads, usually dark at the edges. They may be contaminants from clothing, diapers, toilet paper, etc.

13. PROCEDURE NOTES

- **FDA Status:** FDA Exempt/Cleared or Approved with modification(s).
- **Validated Test Modifications:** None

Routine Urinalysis with Reflexive Microscopic Examination: The following macroscopic abnormalities trigger a microscopic exam.

- Protein: any positive
- Occult Blood: any positive
- Nitrite: any positive
- Leukocyte Esterase: any positive
- Appearance of Cloudy or Turbid

Microscopic examinations on the UF1000i must correlate with Macroscopic results. Flags are built in DI to hold any results that do not correlate for manual microscopic review.

See Addendum 4 *UA Crosschecking – Repeat Criteria*

14. LIMITATIONS OF METHOD

14.1 Precision

The expected %CVs, as specified in the UF-1000i™ Operators Manual:
RBC 10%, WBC 10%, EC 30%, CAST 40%, BACT 10%

14.2 Interfering Substances

Clinitek Novus® 10 Urinalysis Cassette	
Color	Because of the inherent differences between the perception of the human eye and the optical system of the instrument, there may be differences between color that is perceived visually and that is reported by the instrument, especially when there are low levels of color present. Substances that cause abnormal urine color may affect the readability of reagent areas on the urinalysis reagent strips. These substances include visible levels of blood or bilirubin, drugs containing dyes (for example, Pyridium, Azo Gantrisin, Azo Gantanol), nitrofurantoin (Macrochantin, Furadantin), and riboflavin.

Clinitek Novus® 10 Urinalysis Cassette	
SG	Measurement of specific gravity by refractometry may be influenced by high levels of urine glucose and protein which can cause underestimation of the actual specific gravity.
Glucose	Urine samples with a pH of 9.0 and greater will cause falsely elevated glucose results. False positive results may occur in the presence of hypochlorite. A false negative may occur in the presence of acetylcysteine, ascorbic acid, captopril, mesna or curcuma.
Protein	False positive results may be obtained with highly buffered or alkaline urine or in the presence of quinidine, chlorhexidine, chloroquine or Lodine (etodolac). The presence of hemoglobin ($\geq 5\text{mg/dL}$ or 0.05 g/L) may cause elevated results. False negative results may occur if curcuma is present.
Ketone	False trace results may occur with highly pigmented urine specimens or those containing large amounts of levodopa metabolites. Compounds that contain sulfhydryl groups, such as mesna (2-mercaptoethane sulfonic acid) and captopril, as well as acetylcysteine, curcuma, formalin, imipenem or hydrochlorothiazide may cause false positive results or an atypical color reaction. False negative results may occur in the presence of boric acid, formalin, hypochlorite, meropenem or Lodine.
Bilirubin	Indican (indoxyl sulfate) can produce a yellow-orange to red color response that may interfere with the interpretation of a negative or a positive reading. Metabolites of etodolac (Lodine) may cause false positive or atypical results. Atypical colors may indicate the presence of bile pigment abnormalities, and the urine specimen should be tested further. The presence of p-aminosalicylic acid may give a false positive result. A false negative may occur in the presence of acetylcysteine, ascorbic acid, boric acid, hypochlorite, captopril, mesna, nitrite, curcuma, citric acid, chlorhexidine or oxalic acid.
Blood	Captopril (Capoten) and other compounds containing sulfhydryl groups may reduce the sensitivity. Certain oxidizing contaminants, such as hypochlorite, may produce false positive results. Microbial peroxidase associated with urinary tract infection may cause a false positive reaction. False negative results may be obtained in the presence of acetylcysteine, ascorbic acid, formalin, quinidine, cefoxitin, levodopa, mesna, Keflin, curcuma, Lodine, hydrochlorothiazide, metformin, chlorhexidine or chloroquine.
Nitrite	A negative result does not rule out significant bacteriuria. False negative results may occur with shortened bladder incubation of the urine, absence of dietary nitrate or the presence of nonreductive pathological microbes or ascorbic acid, Lodine, formalin, chlorhexidine or oxalic acid. The presence of curcuma or colored precipitates may cause a false positive result.

Clinitek Novus® 10 Urinalysis Cassette	
Leukocyte Esterase	Elevated glucose concentrations ($\geq 3\text{ g/dL}$ or 160 mmol/L) may cause decreased test results. False negative results may occur in the presence of quinidine, boric acid, Tagamet, glycine, chloroquine, sulfamethoxazole, chlorhexidine, nitrofurantoin, Lodine, hypochlorite, glyburide or calcium chloride. The presence of cephalixin (Keflex), cephalothin (Keflin) or high concentrations of oxalic acid may also cause decreased test results. Tetracycline may cause decreased reactivity, and high levels of the drug may cause a false negative reaction. Positive results may occasionally be due to contamination of the specimen by vaginal discharge or the presence of formalin or curcuma. High specific gravity may cause falsely lowered leukocyte results.

14.3 Clinical Sensitivity/Specificity/Predictive Values

Not applicable

15. SAFETY

Refer to the safety manuals and Safety Data Sheet (SDS) for detailed information on safety practices and procedures and a complete description of hazards.

The UF-1000i™ waste is very acidic due to the UF Search-BAC stain. Use caution when handling the UF waste, especially if pouring it into a disposal sink. The waste MUST be treated to reduce the acidity before it is poured into the laboratory waste stream unless the facility has an alternative neutralization process.

Sodium hydroxide (NaOH) is corrosive. Causes severe skin burns and eye damage. Wear protective gloves/protective clothing/eye protection/face protection.
 IF SWALLOWED: Rinse mouth. Do NOT induce vomiting.
 IF ON SKIN: Remove contaminated clothing. Rinse skin with water.
 IF IN EYES: Rinse cautiously with water for several minutes. Remove contact lenses, if present and easy to do. Continue rinsing

16. RELATED DOCUMENTS

- Laboratory QC Program
- Specific Gravity using the Refractometer, Urinalysis procedure
- Urinalysis Clinitek 500, Urinalysis procedure
- Microscopic Examination of Urine, Manual Method, Urinalysis procedure
- Clinitek Novus Maintenance Log (AG.F455)
- UF-1000i Maintenance Log (AG.F456)
- Current Allowable Total Error Specifications at http://questnet1.qdx.com/Business_Groups/Medical/qc/docs/qc_bpt_tea.xls

17. REFERENCES

1. Instructions for Use: Sysmex UF1000i™ Fully Automated Urine Particle Analyzer, Sysmex Corp, Kobe, Japan, Revised 12/09.
2. Instructions for Use: AUW Track, Sysmex Corp, Kobe, Japan, Revised 11/08.
3. Package insert: UF II™ Control, Sysmex Corp, Kobe, Japan, Revised 12/2010
4. Package insert: CLINITEK Atlas Positive and Negative Control Strips for Urinalysis, Siemens Healthcare Diagnostics, Inc. Rev. 09/2014
5. Clinitek Novus® 10 Urinalysis Cassette, Rev. 03/2015
6. Clinitek Novus® Calibration Kit, Rev. 03/2015
7. Clinitek Novus® Rinse Additive, Rev. 11/2015
8. Clinitek Novus® US Only Operator's Guide, Rev.A, 2011-2014 Siemens Healthcare Diagnostics, Inc.
9. Ren C., M. Jin, J. Wu, X. Wang, Y. Wang and H. Cao. 2009. Improving the Detection of Urine Sediment with a Modified Urinalysis Review Procedure. Clin. Lab. 2019;65:507-515
10. Normal Population Reference Ranges (NPRR) for the UF-1000i Analyzer, CLINITEK® AUWi™ System, Siemens Healthcare Diagnostics Inc., Customer Bulletin 2012-05

18. REVISION HISTORY

Version	Date	Section	Reason	Reviser	Approval
1	8/27/19	8.1.A	Added programming for Novus QC to bypass UF module	H Genser	R SanLuis
		8.2	Changed to daily, removed color change	D Collier	R SanLuis
		8.4	Changed sequence of steps	D Collier	R SanLuis
		Add 1	Added weekly maintenance	D Collier	R SanLuis
2	10/8/19	4.1, 4.2	Added 1.0N NaOH	L Barrett	R SanLuis
		4.2	Corrected bleach dilution steps	H Genser	R SanLuis
		5.3	Changed 5.25% to 'diluted bleach'	L Barrett	R SanLuis
		8.2	Updated NaOH instructions	L Barrett	R SanLuis
		10.6	Updated pH code and interpretation	L Barrett	R SanLuis
		15	Added NaOH hazard	L Barrett	R SanLuis
		Add 1	Changed SRV cleaning to weekly	L Barrett	R SanLuis
Add 3	Changed settings for cast & crystals	L Barrett	R SanLuis		

19. ADDENDA

Addendum	Title
1	Maintenance
2	DI (Data Innovations) Information and Actions

Addendum	Title
3	UF1000i Review Criteria
4	UA Crosschecking – Repeat Criteria
5	Novus QC Processing in Unity
6	Loading and Unloading Cassette

Addendum 1:

Maintenance

A. Daily:

UF1000i “Shutdown”	
1.	On the Menu screen, click on Shutdown
2.	Select Yes in the shutdown dialog box
3.	Press the Manual analysis start switch
4.	After shutdown is completed, the power of the Main Unit is automatically turned OFF START-UP: To re-start the UF depress the power switch on the front of the UF. Startup occurs after a short delay. The instrument will automatically perform a background check. Print and file the back-ground check results.

Clinitek Novus “Cleaning the Specific Gravity Well”	
1.	Pour at least 2 mL of diluted bleach 5.25% sodium hypochlorite solution into a sample tube
2.	Place the tube in the STAT Holder , then push it forward until it stops moving
3.	On the Clinitek Novus’ screen select System > Clean SG Well > Start
4.	When cleaning is done, press the “ Push Button ” to release the STAT Holder to its home position

B. Weekly:

Reboot Computer	
1.	During daily shutdown (while UF is powered down), power down the computer
2.	Stop / close the IPU and WAM programs.
3.	Go to the Start icon on lower left side of screen, and shutdown
4.	Power up the computer
5.	Log back into the computer, and then the IPU and WAM programs

UF1000i “Cleaning the Sample Rotor Valve (SRV)”	
1.	SRV needs to be cleaned either monthly or every 9,000 cycles. If 9,000 or more samples have been analyzed since the previous washing, the message “Wash the sample rotor valve” will appear after switching the instrument on.
2.	Make sure the power to the Main Unit is OFF
3.	Wait 1 minute while the vacuum and pressure are released
4.	Open the front cover of the instrument
5.	Turn the fixing screw counterclockwise, then remove it from the SRV mounting shaft
6.	Remove the front fixed valve and SRV. Pull the parts gently, and carefully twist them off

UF1000i “Cleaning the Sample Rotor Valve (SRV)”	
7.	Use a damped gauze to clean the surface of both parts
8.	Put the parts back together, then turn the fixing screws clockwise to tighten them against the shaft with a gap of about 1mm
9.	Clean and dry the tray
10.	Clove the front cover, switch on the Main Unit.
11.	On the Menu screen from the IPU click on the Controller > Maintenance > Counter > Reset

C. As needed:

UF1000i “Trap Chamber”	
1.	Check the volume of water in the trap chamber and discard if any has accumulated.
2.	Switch the Main Unit off
3.	Wait 1 minute while the vacuum and pressure are released
4.	Open the front cover of the instrument
5.	Turn the Trap Chamber and remove it
6.	Discard the fluid then tighten the chamber

Directions for other maintenance not listed in this procedure can be located in the Operator’s Guide.

Addendum 2:

DI (Data Innovations) Information and Actions

1. Urinalysis SM Workspace Overview

Results from the Auwi Pro display in DI using the Run Worksheet

- Results from a run display in a single result column and are divided into groups
- Successive runs display on the next result column

Cell Counter Tab for the UA Keyboard

Test Name	Result (1)	Test Status	Units (1)	Test	Error Code(s) (1)	Error Name(s) (1)	Test C.	Result Date/Time	Result (2)	Test Status
FLAGS										
UF Path Cast Flag	PRESE...	Held for V...		SAU		Check for presence of Casts		7/11/2019		
UF SRC Flag	PRESE...	Held for V...		SAU		Check for presence of Transition...		7/11/2019		
UF XTAL Flag	PRESE...	Held for V...		SAU		Check for presence of Crystals		7/11/2019		
UF YLCF Flag	PRESE...	Held for V...		SAU		Check for presence of Yeast		7/11/2019		
URINE CHEMISTRY										
Bilirubin	NEG	Held for V...	mg/dL	SAU	HOLD	Other Tests Held		7/11/2019		
Blood	NEG	Held for V...	mg/dL	SAU	Correlation	Verify Results		7/11/2019		
Clarity	CLER	Held for V...		SAU		Other Tests Held		7/11/2019		
Color	YEL	Held for V...		SAU		Other Tests Held		7/11/2019		
Glucose Urine	NEG	Held for V...	mg/dL	SAU		Other Tests Held		7/11/2019		
Ketone	NEG	Held for V...	mg/dL	SAU	HOLD	Other Tests Held		7/11/2019		
Leukocytes	NEG	Held for V...	Leu/uL	SAU	Correlation	Verify Results		7/11/2019		
Nitrite	NEG	Held for V...		SAU	HOLD	Other Tests Held		7/11/2019		
pH	8.0	Held for V...		SAU	HOLD	Other Tests Held		7/11/2019		
Protein	NEG	Held for V...	mg/dL	SAU	HOLD	Other Tests Held		7/11/2019		
Specific Gravity	1.025	Held for V...		SAU	HOLD	Other Tests Held		7/11/2019		
Urobilinogen	0.2	Held for V...	EU/dL	SAU	HOLD	Other Tests Held		7/11/2019		
AUTOMATED MICROSCOPY										
WBC Urine	021	Held for V...	/HPF	SAU	Correlation	Verify Results		7/11/2019		
RBC Urine	021	Held for V...	/HPF	SAU	Correlation	Verify Results		7/11/2019		
Squamous Epithelial	1+	Held for V...	/LPF	SAU	HOLD	Other Tests Held		7/11/2019		
Hyaline Cast	011	Held for V...	/LPF	SAU	HOLD	Other Tests Held		7/11/2019		
Bacteria	1+	Held for V...	/HPF	SAU	HOLD	Other Tests Held		7/11/2019		
UTYPE	DONE	Held for V...		SAU	HOLD	Other Tests Held		7/11/2019		
MANUAL MICROSCOPY										
Budding Yeast									1+	Held for V...
Calcium Oxalate Crystal									1+	Held for V...
Transitional Epithelial									1+	Held for V...

Run #1 (points to first column of results)
 Run #2 (points to second column of results)

2. Urinalysis Run Worksheet Test Grouping

The Urinalysis RunWorksheet is divided into four groups:

- Flags
- Urine Chemistry
- Automated Microscopy
- Manual Microscopy

Test Name	Result (1)	Test Status	Units (1)
FLAGS			
UF Path Cast Flag	PRESE...	Held for V...	
UF SRC Flag	PRESE...	Held for V...	
UF XTAL Flag	PRESE...	Held for V...	
UF YLCF Flag	PRESE...	Held for V...	
URINE CHEMISTRY			
Bilirubin	NEG	Held for V...	mg/dL
Blood	NEG	Held for V...	mg/dL
Clarity	CLER	Held for V...	
Color	YEL	Held for V...	
Glucose Urine	NEG	Held for V...	mg/dL
Ketone	NEG	Held for V...	mg/dL
Leukocytes	NEG	Held for V...	Leu/uL
Nitrite	NEG	Held for V...	
pH	8.0	Held for V...	
Protein	NEG	Held for V...	mg/dL
Specific Gravity	1.025	Held for V...	
Urobilinogen	0.2	Held for V...	EU/dL
AUTOMATED MICROSCOPY			
WBC Urine	021	Held for V...	/HPF
RBC Urine	021	Held for V...	/HPF
Squamous Epithelial	1+	Held for V...	/LPF
Hyaline Cast	011	Held for V...	/LPF
Bacteria	1+	Held for V...	/HPF
UTYPE	DONE	Held for V...	
MANUAL MICROSCOPY			
Budding Yeast			
Calcium Oxalate Crystal			
Transitional Epithelial			

FLAG grouping shows the instrument's abnormal result flags

URINE CHEMISTRY grouping displays the results from the Clinitek Novus instrument

AUTOMATED MICROSCOPY grouping displays the results from the Sysmex UF-1000i instrument

MANUAL MICROSCOPY grouping displays the results from the UA Keyboard

3. Result Processing

A. Changing Result using Insert Coded Entry

- Right click on the result field to be edited
- Select **“Insert Coded Entry.”** The Insert Coded Entry window will display
- Select the appropriate code and click **OK** to close the window

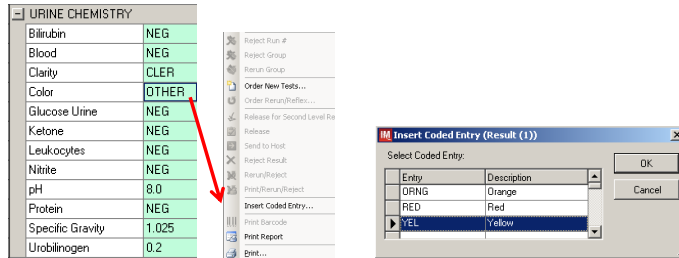

B. Positive Bilirubin

If Bilirubin is resulted with 1+, 2+ or 3+, DI will add the English text code **UPPB** to the test comment. UPPB translates to “Presumptive positive bilirubin. Consider confirmation by serum bilirubin if clinically indicated.”

Run Worksheet							
Test Name	Result (1)	Test Statu...	Units (1)	Test...	Error Code(s) (1)	Error Name(s) (1)	Test Comment(s) (1)
CHEMISTRY							
Bilirubin	1+	Held for V...	mg/dL	SAU	HOLD	Other Tests Held	UPPB
Glucose Urine	NEG	Held for V...	mg/dL	SAU	HOLD	Other Tests Held	

C. pH of >9.0

If the pH is >=9.0, DI will replace the results for glucose and protein with **UAMUP** and hold the results for review. The code translates to “Unable to accurately measure urine protein or glucose when pH is >9.0”

Glucose Urine	UAMUP	Held for V...	mg/dL	SAU	HOLD	Result replaced with UAMUP
Ketone	NEG	Held for V...	mg/dL	SAU	HOLD	Other Tests Held
Leukocytes	NEG	Held for V...	Leu/uL	SAU	Correlation	Verify Results
Nitrite	NEG	Held for V...		SAU	HOLD	Other Tests Held
pH	>=9.0	Held for V...		SAU	HOLD	Other Tests Held
Protein	UAMUP	Held for V...	mg/dL	SAU	HOLD	Result replaced with UAMUP

D. Resulting Automated Microscopic results with “????,” “****,” or “----“

DI will automatically reject the automated microscopic results with “????,” “****,” or “----“and display the error message “Verify with Microscopy.” Result the test using the DI Urinalysis Keyboard

Test Name	Result (1)	Test Statu...	Units (1)	Test...	Error Code(s) (1)	Error Name(s) (1)
AUTOMATED MICROSCOPY						
UEC	1+	Held for V...	/LPF	SAU	HOLD	Other Tests Held
Bacteria	---	Rejected	/HPF	SAU	Verify with Microscopy	Verify with Microscopy
Hyaline Cast	01	Held for V...	/LPF	SAU	HOLD	Other Tests Held
RBC Urine	2222	Rejected	/HPF	SAU	Verify with Microscopy	Verify with Microscopy
WBC Urine	2222	Rejected	/HPF	SAU	Verify with Microscopy	Verify with Microscopy

E. UCOL (Color) Resulted with OTHER

Test Name	Result (1)	Test Statu...	Units (1)	Test...	Error Code(s) (1)	Error Name(s) (1)
URINE CHEMISTRY						
Bilirubin	NEG	Held for V...	mg/dL	SAU	HOLD	Other Tests Held
Blood	NEG	Held for V...	mg/dL	SAU	Correlation	Verify Results
Clarity	CLER	Held for V...		SAU	HOLD	Other Tests Held
Color	OTHER	Held for V...		SAU	Check Specimen	Specify Color

If the Novus results the urine color as “OTHER,“ DI will hold the results and display “Check Specimen” and “Specify Color.” Follow the steps for “Changing Result using Insert Coded Entry” to change the color. Below are the colors available:

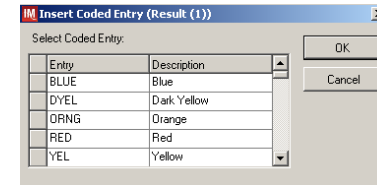

F. Resulting Specific Gravity >1.030

If the specific gravity is >1.030, then the result will be suppressed and the error message of “Confirm with Refractometer” will be displayed

Specific Gravity		Held for V...		SAU	Check USPG	Confirm with Refractometer
------------------	--	---------------	--	-----	------------	----------------------------

If manual refractometer result is >1.030, then replace the results with >1.030 by using the “Insert Coded Entry”

4. Performing Manual Microscopy using the Urinalysis Keyboard

The Urinalysis keyboard is used to enter the observational results from the manual microscopy. Each test on the keyboard can be resulted by left-clicking on the result field for that test and selecting the drop-down arrow to reveal a list of available results.

Occasionally a result from the automated microscopy may have an unacceptable result such as “???” “*****” or “----.” In this situation, perform manual microscopy and check for presence of that formed element. There is no need to repeat other results from the automated microscopy when doing the manual microscopy.

Example:

If the bacteria from the automated microscopy is resulted with 1+, there is no need to result the bacteria in the manual microscopy. However, when the bacteria is resulted with “???” and the rest of the automated microscopy results are acceptable (see 10.4 for acceptable microscopic result parameters), DI will reject the bacteria result and the bacteria must be resulted with the manual microscopy. The rest of the automated microscopy results such as the RBC, WBC, hyaline cast and squamous epithelial can be resulted along with other formed elements, cast, or crystal seen.

Test Code	Result	Units
* []		
- FORMED ELEMENTS		
RBC Urine		/HPF
WBC Urine		/HPF
Bacteria		/HPF
Squamous Epithelial		/LPF
Renal Epithelial		/HPF
Transitional Epithelial		/HPF
Mucus		/LPF
Trichomonas		
Budding Yeast		/HPF
Hyphae Yeast		/HPF
Oval Fat Body		/HPF
Enterobius Vermicularis		
Schistoma Haematobium		
Sperm		
- CAST		
Broad Cast		/LPF
Cellular Cast		/LPF
Epithelial Cast		/LPF
Fatty Cast		/LPF
Granular Cast		/LPF
Hemoglobin Cast		/LPF
Hyaline Cast		/LPF
RBC Cast		/LPF
Waxy Cast		/LPF
WBC Cast		/LPF
- CRYSTAL		
Ammonium Biurate		/HPF
Calcium Carbonate Crystal		/HPF
Calcium Oxalate Crystal		/HPF
Calcium Phosphate Crystal		/HPF
Calcium Sulfate Crystal		/HPF
Cholesterol Crystal		/HPF
Cystine Crystal		/HPF
Hippuric Acid Crystal		/HPF
Leucine Crystal		/HPF
Sodium Urate Crystal		/HPF
Triple Phosphates Crystal		/HPF
Tyrosine Crystal		/HPF
Sulfa drug Crystal		/HPF
Uric Acid Crystal		/HPF

5. Order of Release

The Urinalysis results consist of 3 to 4 groups in DI. They must be released in DI in a certain order to ensure proper filing into Sunquest. The order is explained below.

- Note:** To release or reject a group, follow the steps below:
- Right click on the test to be released/rejected
 - If “Release URINE CHEMISTRY/Reject Other Runs” is selected, DI will release the selected Urine Chemistry group and reject other Urine Chemistry group from a different run

To Reject a test, follow the steps below:

- Right click on the test to be rejected
- If “Reject Result” is selected, DI will reject that result. Once rejected, that result can no longer be released from DI.

Results with just Urine Chemistry

- Release the Urine Chemistry group

Results with Urine Chemistry and Automated Microscopy

- Release the Chemistry group
- Release the Automated Microscopy group

Results with Urine Chemistry, Automated Microscopy and Manual Microscopy (no duplicate)

Note: Before releasing the results, it is important that the manual microscopy group does not have a duplicate test with the automated microscopy group. If there is a duplicate test, reject the duplicate test first from the automated group and release the microscopic result.

- Release the Chemistry group
- Release the Automated Microscopy group
- Reject the duplicate test if there is any
- Release the Manual Microscopy group

6. Microscopic Billing

DI will add a billing testcode of UTYP to the automated microscopy group whenever there is a microscopic test done. This test code is resulted with “DONE.” This test code must be released together with the rest of the Automated Microscopy group.

Test Name	Result (1)	Test Statu...	Units (1)	Test ...
- AUTOMATED MICROSCOPY				
Hyaline Cast	01	Held for V...	/LPF	SAU
Bacteria	3+	Held for V...	/HPF	SAU
LWBC	06	Held for V...	/HPF	SAU
URBC	TNTC	Held for V...	/HPF	SAU
UEC	2+	Held for V...	/LPF	SAU
UTYP	DONE	Held for V...		SAU

Addendum 3:

UF1000i Review Criteria

Analyte	Instrument Setting	Instrument Flag	Action
PATH CAST	1.0/uL 2.22/ uL	Path.Cast +	Examine sediment for presence of pathological casts. Identify and enumerate.
SRC (Small Round Cells)	8.2/uL	SRC +	Examine sediment for presence of small round cells. Identify and enumerate.
CRYSTALS	25.0/uL 100.0/uL	X*TAL +	Examine sediment for presence of crystals. Identify and rank few, 1+, 2+, 3+.
YEAST	25.0/uL	YLC +	Examine sediment for presence of yeast like cells. Identify and rank occasional, 1+, 2+, 3+, 4+.
WBC, RBC, EC, BAC, HY/C	N/A	---- (vote out) or *	Examine sediment for the presence of formed elements. Always report WBC, RBC, Epithelial Cells, Bacteria and Hyaline Casts.
CASTS	>10 HYAL seen	>10/uL	Examine sediment to verify presence and enumeration of hyaline casts.

Addendum 4:

UA Crosschecking – Repeat Criteria

Chemistry Result	Microscopic Findings	Error Message Displayed on DI	Action
pH = 1 to 6.5 (acidic)	Acidic Crystals are seen: Triple phosphate, Calcium phosphate, and/or Calcium Carbonate	Check pH, Crystals Inconsistent with pH	Verify Results
pH = 7.5 to 14 (alkaline)	Alkaline Crystals are seen: Calcium Oxalate, Cystine, Tyrosine, Uric acid, and/or Leucine	Check pH, Crystals Inconsistent with pH	Verify Results
Leukocyte esterase is Negative	WBC is resulted with >=6 /LPF	Verify Results	Verify Results
Leukocyte esterase is Positive (1+ or greater)	WBC is resulted with 0-2/LPF	Verify Results	Verify Results
Nitrite is Positive	Bacteria is Negative	Verify Results	Verify Results
Occult Blood is Negative	RBC is resulted with >3 /LPF	Verify Results	Verify Results
Occult Blood is Positive (1+ or greater)	RBC is resulted with 0-2/LPF	Verify Results	Verify Results
Protein is Negative	>11 Hyaline Cast seen	Verify Results	Verify Results

Addendum 5:

Novus QC Processing in Unity

A. To enter QC results in Unity Real Time using Multi Test Data Entry:

1. Log into Unity Real Time
2. Select Lab “SGMC AuWi Pro” or “WOMC AuWi Pro”
3. Select the control level that you want to enter QC data for

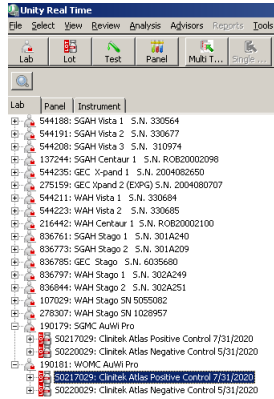

4. Select the “Multi Test Data Entry” icon



5. The “Multi Test Data Entry” dialog box will open.

These settings are selected by default. There is no need to edit them

- Set Date: Set to current date and time
- Lab: Set to the site specific instrument
- Lot: Set to the level of QC.
- Display: Set to Analyte
- Entered by: Set to Row

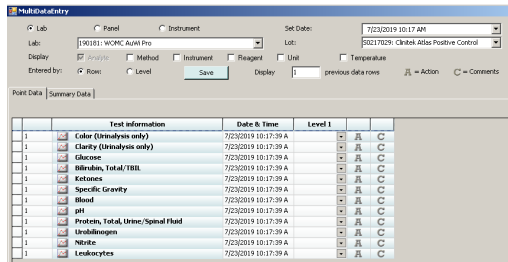

6. Select **Point Data** to display the list of tests
7. Enter the QC data by using the drop down menu provided for each test

	Test information	Date & Time	Level 1		
1	Color (Urinalysis only)	7/23/2019 10:42:28 A	Yellow	A	C
1	Clarity (Urinalysis only)	7/23/2019 10:42:28 A	Cloudy	A	C
1	Glucose	7/23/2019 10:42:28 A	1+	A	C
1	Bilirubin, Total/TBIL	7/23/2019 10:42:28 A	Negative	A	C

8. If the value entered is not expected, Unity will turn the response field to red. Enter an Action or Comment

	Test information	Date & Time	Level 1		
1	Color (Urinalysis only)	7/23/2019 10:17:39 A	Yellow	A	C
1	Clarity (Urinalysis only)	7/23/2019 10:17:39 A	Cloudy	A	C
1	Glucose	7/23/2019 10:17:39 A	1+	A	C
1	Bilirubin, Total/TBIL	7/23/2019 10:17:39 A	Negative	A	C
1	Ketones	7/23/2019 10:17:39 A	Negative	A	C
1	Specific Gravity	7/23/2019 10:17:39 A	1.004	A	C
1	Blood	7/23/2019 10:17:39 A	Negative	A	C
1	pH	7/23/2019 10:17:39 A	6.0	A	C
1	Protein, Total, Urine/Spinal Fluid	7/23/2019 10:17:39 A	Negative	A	C
1	Urobilinogen	7/23/2019 10:17:39 A	1.0	A	C
1	Nitrite	7/23/2019 10:17:39 A	Positive	A	C
1	Leukocytes	7/23/2019 10:17:39 A	Negative	A	C

9. Click on **Save** to save the data entered

Note: Data can't be saved without documenting the corrective action performed. This pop-up box will show

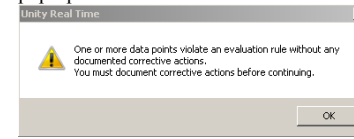

10. Select the next level of QC by clicking on the **Lot** drop down menu.
11. To enter data, repeat steps 6 to 8

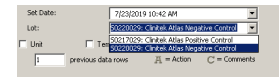

B. Expected QC Results from Clinitek Novus Analyzer

Test	Positive Control	Negative Control
Color	Yellow - Orange	Yellow, Green, or Other
Clarity	Clear	Clear
Glucose	100 - 500 mg/dL	Negative
Bilirubin	Small - Large	Negative
Ketone	Trace - Large	Negative
Specific Gravity	<=1.006	1.004 – 1.014
Occult Blood	Large	Negative
pH	>=8.0	6.0 – 7.0
Protein	10– 100 mg/dL	Negative
Urobilinogen	1.0 – 2.0 EU/dL	0.2 – 1.0 EU/dL
Nitrite	Positive	Negative
Leukocytes	Small-Large	Negative

Addendum 6

Unloading and Loading a Cassette



CAUTION

Do not leave the cassette compartment moisture gate open for longer than 10 minutes when a cassette is in the compartment. Humidity causes the test pads to deteriorate. If the system displays a message that the cassette is invalid, or if the cassette compartment moisture gate has been opened for 10 minutes or more, replace the cassette. The system will inform you if the cassette is invalid and will not process tests until a valid cassette is loaded.

1. Select **System > Load & Unload**.
2. If a cassette is already loaded in the cassette compartment, to confirm unloading the cassette, select **Yes**.

The cassette compartment moisture gate will open. If a test card is on the card platform, the system ejects the card. The moisture gate will remain open until the cassette compartment door is unlocked and re- locked.

3. When prompted, open the system cover.
4. To unlock the cassette compartment door, turn the lock counterclockwise, and then open the door.

Figure 2-2: Unlocking the Cassette Compartment Door

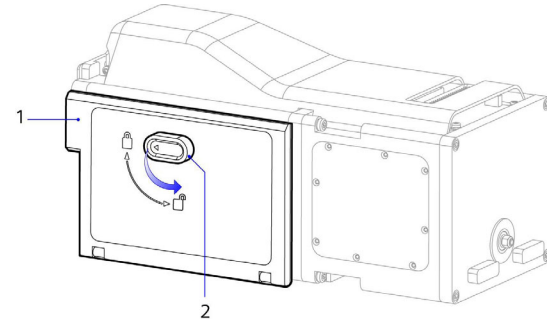

- 1 Cassette compartment door
- 2 Cassette lock

5. Hold the cassette by its handle in the front, and slide the cassette toward you on the cassette compartment rails.

Figure 2-3: Unloading the Cassette

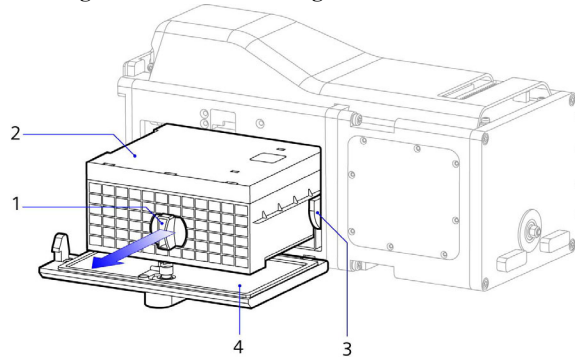

-
- 1 Cassette handle
 - 2 Cassette
 - 3 Cassette compartment rail
 - 4 Cassette compartment door
-



CAUTION
Do not use any test cards that fall out of the cassette. Dispose of them.

6. To load the new cassette, hold the cassette by its handle in the front, and slide the cassette into the cassette compartment using the rails as your guide.

Figure 2-4: Loading the New Cassette

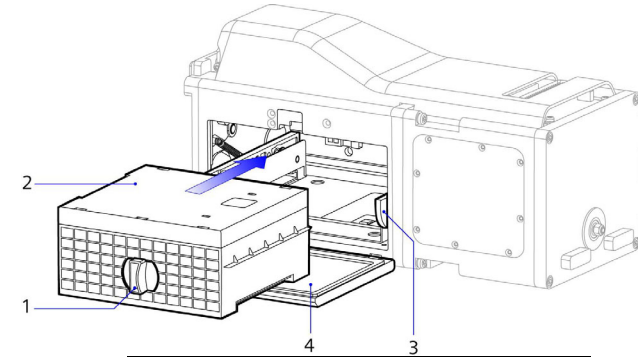

-
- 1 Cassette handle
 - 2 Cassette
 - 3 Cassette compartment rail
 - 4 Cassette compartment door
-

7. Close the cassette compartment door and turn the lock clockwise to lock the door.

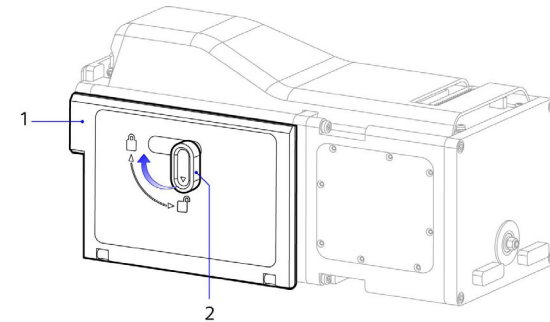

Figure 2-5: Locking the Cassette Compartment Door

-
- 1 Cassette compartment door
 - 2 Cassette lock
-

8. Close the system cover.
The system reads the lot number and expiration date from the cassette.